

# REPORT

**Contract: 11245 UEP II**  
Final version, **Date: 21.08.2013**

Cicerostr. 24  
D-10709 Berlin  
Germany  
Tel +49 (0)30 536 53 800  
Fax +49 (0)30 536 53 888  
www.kompetenz-wasser.de

## Tertiary treatment combining ozonation and membrane filtration – Pilot scale investigations

### Project acronym: OXERAM 2

by

Johan Stüber

Kompetenzzentrum Wasser Berlin gGmbH

Cicerostr. 24, 10709 Berlin, Germany

and

Manuel Godehardt

Technische Universität Berlin, Department of Water Quality Control

for

Kompetenzzentrum Wasser Berlin gGmbH

Preparation of this report was financed through funds provided by Berliner  
Wasserbetriebe, Veolia Water and Berlin Environmental Relief Programme (ERP)



Project co-financed by the  
Berlin Senate and the  
European Union.

(European Regional  
Development Fund)

Investing in your Future!



Senate Department  
for Urban Development  
and the Environment



Berlin, Germany  
2013



### **Important Legal Notice**

**Disclaimer:** The information in this publication was considered technically sound by the consensus of persons engaged in the development and approval of the document at the time it was developed. KWB disclaims liability to the full extent for any personal injury, property, or other damages of any nature whatsoever, whether special, indirect, consequential, or compensatory, directly or indirectly resulting from the publication, use of application, or reliance on this document. KWB disclaims and makes no guaranty or warranty, expressed or implied, as to the accuracy or completeness of any information published herein. It is expressly pointed out that the information and results given in this publication may be out of date due to subsequent modifications. In addition, KWB disclaims and makes no warranty that the information in this document will fulfill any of your particular purposes or needs. The disclaimer on hand neither seeks to restrict nor to exclude KWB's liability against all relevant national statutory provisions.

### **Wichtiger rechtlicher Hinweis**

**Haftungsausschluss:** Die in dieser Publikation bereitgestellte Information wurde zum Zeitpunkt der Erstellung im Konsens mit den bei Entwicklung und Anfertigung des Dokumentes beteiligten Personen als technisch einwandfrei befunden. KWB schließt vollumfänglich die Haftung für jegliche Personen-, Sach- oder sonstige Schäden aus, ungeachtet ob diese speziell, indirekt, nachfolgend oder kompensatorisch, mittelbar oder unmittelbar sind oder direkt oder indirekt von dieser Publikation, einer Anwendung oder dem Vertrauen in dieses Dokument herrühren. KWB übernimmt keine Garantie und macht keine Zusicherungen ausdrücklicher oder stillschweigender Art bezüglich der Richtigkeit oder Vollständigkeit jeglicher Information hierin. Es wird ausdrücklich darauf hingewiesen, dass die in der Publikation gegebenen Informationen und Ergebnisse aufgrund nachfolgender Änderungen nicht mehr aktuell sein können. Weiterhin lehnt KWB die Haftung ab und übernimmt keine Garantie, dass die in diesem Dokument enthaltenen Informationen der Erfüllung Ihrer besonderen Zwecke oder Ansprüche dienlich sind. Mit der vorliegenden Haftungsausschlussklausel wird weder bezweckt, die Haftung der KWB entgegen den einschlägigen nationalen Rechtsvorschriften einzuschränken noch sie in Fällen auszuschließen, in denen ein Ausschluss nach diesen Rechtsvorschriften nicht möglich ist.

## Colophon

Present report was developed in compliance with the requirements of the quality management system DIN EN ISO 9001:2008

### Title

Tertiary treatment combining ozonation and membrane filtration – Pilot scale investigations

### Authors

Johan Stüber, Kompetenzzentrum Wasser Berlin gGmbH

Manuel Godehardt, FG Wasserreinhaltung, TU Berlin

### Quality Assurance

Annie Tazi-Pain, Veolia

Ulf Miehe, Kompetenzzentrum Wasser Berlin gGmbH

Boris Lesjean, Kompetenzzentrum Wasser Berlin gGmbH

Publication / Dissemination approved by technical committee members:

C. Bourdon, Veolia

A. Tazi-Pain, Veolia

C. Bartholomäus, Berliner Wasserbetriebe

R. Gnirß, Berliner Wasserbetriebe

A. Peter-Fröhlich, Berliner Wasserbetriebe

M. Jekel, FG Wasserreinhaltung, TU Berlin

A. Hartmann, Kompetenzzentrum Wasser Berlin gGmbH

Deliverable number

D 2.2

Final version

Date: 21.08.2013

## Abstract (English)

Within the project OXERAM state of the art membrane filtration was applied as a tertiary treatment step for advanced phosphorus removal in a municipal wastewater treatment plant. Two membrane types, ceramic and polymeric, were tested in pilot scale, using commercial membrane modules. Due to the drawback of membrane fouling, leading to comparably high investment and operating costs, pre-treatment with ozone was tested. Ozonation was expected to increase the sustainable flux for both membrane types.

For both membranes types high filtrate quality was achieved. A mean total phosphorus concentration below 25 µg/L was achieved over two years. Additionally disinfection is reached and therefore the European bathing water standards were met. The effect of ozonation and coagulation on various water quality parameters were evaluated and are presented in this report.

Ultrafiltration modules (0.02 µm) made of polyether sulfone (PES) were tested comparing different capillary diameters (0.9 vs. 1.5 mm) leading to different package densities (respectively 40 and 60 m<sup>2</sup> per module). Both types were operated in parallel and the experience showed a more robust operation with 1.5 mm capillaries when applying high fluxes targeting high recoveries. Both evaluation parameters, total fouling rate and membrane regeneration by cleaning in place, suggested the 1.5 mm module for the application at the WWTP Ruhleben. Optimizing the operation set up and cleaning strategy proved that recoveries ≥ 95 % could be achieved and therefore a second filtration unit treating the backwash water is obsolete. The design with max 75 L/(m<sup>2</sup>h), 60 minutes of filtration, and a backwash duration of 40 s is the proposed set up for WWTP Ruhleben. A daily acidic chemical enhanced backwash combined with a weekly caustic cleaning step proved to manage the fouling affinity and a cleaning in place interval of 1 – 3 months was demonstrated in a long term run. The usage of ozone did not improve the overall filtration performance, because the benefit of a higher filterability is compensated by a higher additional fouling resistance after each backwash. Therefore the mean trans-membrane pressure remains in the same range. These results were only collected with the combination of ozonation and PES ultrafiltration membranes. Lab scale tests conducted at the Chair of Water Quality, TU Berlin, confirm this outcome but showed different results for other membrane materials and pore sizes.

The potential to reduce the total fouling rate combining ozonation with coagulation prior ceramic membrane filtration was shown. A microfiltration membrane (0.1 µm) consisting of Al<sub>2</sub>O<sub>3</sub> and a surface of 25 m<sup>2</sup> was tested in pilot scale. Applying a dose of 15 mgO<sub>3</sub>/L (z = 1.18 mgO<sub>3</sub>/mgDOC) could reduce the total fouling rate by half even when doubling the flux from 60 L/(m<sup>2</sup>h) to 120 L/(m<sup>2</sup>h). Critical flux experiments showed that the application of 7.5 mgO<sub>3</sub>/L (z = 0.7 mgO<sub>3</sub>/mgDOC) was sufficient to recognize the beneficial effect of pre-ozonation. Treating the secondary effluent of WWTP Ruhleben a sustainable flux around 130 – 140 L/(m<sup>2</sup>h) was identified when applying pre-ozonation of 7.5 mgO<sub>3</sub>/L (z = 0.7 mgO<sub>3</sub>/mgDOC) and 8 mgFe/L for coagulation. It was not possible to demonstrate this process set up in a long term run, due to technical malfunctions. An economic evaluation showed however that for the case of WWTP Ruhleben a sustainable flux > 500 L/(m<sup>2</sup>h) is required to be competitive against tertiary treatment with polymeric membranes without ozone. This high value can be explained by the high module cost for ceramic membranes and the high DOC content of the secondary effluent, leading to increased effort for ozonation.

## Abstract (German)

Das Projekt OXERAM vergleicht im Parallelbetrieb verschiedene Technologien für die vierte Reinigungsstufe kommunaler Klärwerke am Standort Ruhleben, Berlin. Membranfiltration erreicht durch den vollständigen Rückhalt der Feststoffe und der Desinfektion eine hohe Filtratqualität. Diese hohe Reinigungsleistung wird durch einen erhöhten Energie- und Chemikalieneinsatz erkauft. Das „Fouling“ der Membranen führt zu einem unerwünschten Mehraufwand, so dass ein wirtschaftlicher Betrieb im Vergleich zu konventionellen Technologien fraglich erscheint. Aus diesem Grund wurde der Einfluss einer Vorbehandlung mit Ozon auf die Filtrationsleistung und das „Fouling“ untersucht. Um eine realistische Übertragung der gewonnenen Ergebnisse auf einen großtechnischen Maßstab zu gewährleisten, wurden die Versuche mit kommerziellen Membranmodulen im Pilotmaßstab durchgeführt. Untersucht wurden sowohl eine keramische Membran ( $\text{Al}_2\text{O}_3$ , Mikrofiltration  $0,1 \mu\text{m}$ ) als auch verschiedene Baureihen einer organischen Hohlfasermembran (PES, Ultrafiltration  $0,02 \mu\text{m}$ ).

Die hohe Reinigungsleistung konnte für beide Membrantypen nachgewiesen werden. Die Gesamtposphorkonzentration im Filtrat lag im Mittel über die zwei Jahre unter  $25 \mu\text{g/L}$ . Durch die Desinfektion konnten die Grenzwerte gemäß der europäischen Badewasserverordnung eingehalten werden. Der Einfluss der Ozonung und Fällung auf den Betrieb und die verschiedenen Wasserparameter wird in diesem Bericht vorgestellt.

Der Durchmesser der Kapillaren bestimmt bei den organischen Hohlfasermembranen die Packungsdichte und damit in erheblichem Umfang die Investitionskosten. Am Standort Ruhleben wurden Module mit  $1,5 \text{ mm}$  ( $40 \text{ m}^2$ ) mit Modulen mit  $0,9 \text{ mm}$  ( $60 \text{ m}^2$ ) verglichen. Bei einer vergleichsweise hohen Flächenbelastung, welche auf eine hohe Ausbeute abzielt, konnte das  $1,5 \text{ mm}$  Modul stabiler betrieben werden. Sowohl die Gesamtfoulingrate, als auch die Ertüchtigung der Membran durch eine intensive chemische Reinigung waren bei diesem Modul vorteilhaft. Durch eine angepasste Betriebsführung waren Ausbeuten  $\geq 95 \%$  langfristig zu erreichen, wodurch eine zweite Filtrationsstufe zur Behandlung des Rückspülwassers wegfällt. Dies reduziert die Investitionskosten erheblich. Die vorgeschlagene Betriebsweise,  $75 \text{ L}/(\text{m}^2\text{h})$ ,  $8 \text{ mgFe/L}$  (bzw.  $3,81 \text{ mgAl/L}$ ) bei einer Filtrationsdauer von 60 Minuten, wurde in einem Langzeitversuch demonstriert. Dabei konnte außerdem folgende Reinigungsstrategie getestet werden: Eine tägliche saure chemische Spülung, sowie eine wöchentliche alkalische, führen zu einem Betriebsintervall von 1 – 3 Monaten bevor eine intensive chemische Reinigung erforderlich ist. Mit der Kombination von Ozon und der verwendeten PES Ultrafiltrationsmembran konnte keine Leistungssteigerung erzielt werden, da zwar durch die Ozonung das Wasser der Foulingwiderstand am Ende eines Filtrationszyklusses verringert, gleichzeitig aber am Anfang erhöht wird. Hierdurch bleibt der durchschnittliche Transmembrandruck gleich. Diese Ergebnisse gelten nur für die betrachtete Ultrafiltrationsmembran aus PES und Laboruntersuchungen des FG Wasserreinigung, TU Berlin, zeigen dass unter Verwendung anderer Membranmaterialien und Porengrößen die Resultate abweichen können.

Das Potenzial zur Verringerung der Foulingrate konnte bei den Versuchen mit der keramischen Membran nachgewiesen werden. Bei einer Ozondosis von  $15 \text{ mgO}_3/\text{L}$  ( $z = 1,17 \text{ mgO}_3/\text{mgDOC}$ ) wurde die Foulingrate um die Hälfte reduziert, bei gleichzeitiger Verdopplung der Flächenbelastung ( $120 \text{ L}/(\text{m}^2\text{h})$  anstatt  $60 \text{ L}/(\text{m}^2\text{h})$ ). Durch Versuche zur Bestimmung des „critical flux“ konnte gezeigt werden, dass durch Einsatz einer mittleren Ozondosis von  $7,5 \text{ mgO}_3/\text{L}$  ( $z = 0,7 \text{ mgO}_3/\text{mgDOC}$ ) dieser angehoben werden kann.

Eine weitere Erhöhung der Ozondosis bewirkte nur noch eine geringfügige Steigerung. Ein „sustainable flux“ von 130 – 140 L/(m<sup>2</sup>h) wurde bei einer Kombination von 7,5 mgO<sub>3</sub>/L und 8 mgFe/L ermittelt. Aufgrund von Ausfällen der Prozesstechnik konnte diese Betriebsführung nicht im Langzeitbetrieb nachgewiesen werden. Eine Wirtschaftlichkeitsbetrachtung ergab, dass eine Flächenbelastung  $\geq 500$  L/(m<sup>2</sup>h) durch eine Ozonung mit 7,5 mgO<sub>3</sub>/L erreicht werden muss, damit eine Filtrationsstufe mit keramischen Membranen im Vergleich zu den organischen Membranen (ohne Ozonung) wirtschaftlich konkurrenzfähig ist. Dieses Ergebnis kann mit den hohen Modulpreisen der keramischen Membranen und der vergleichsweise hohen DOC-Konzentration im Ablauf der Kläranlage Ruhleben erklärt werden, welche einen vermehrten Aufwand für die Ozonung mit sich bringt.

## Acknowledgements

Countless people are involved conducting a long term research project in pilot scale as presented in this report. The authors and the whole OXERAM team would like to acknowledge all our colleagues and partners who helped throughout the project during many fruitful discussions. We would also like to express our gratitude to our collaborators, interns, and Master/Diploma students for supporting us in the every-day work on-site and in the laboratories.

In particular we want to thank:

### *Berliner Wasserbetriebe*

Regina Gnirß, Alexander Sperlich (BWB-FE)

Michael Kempf, Rolf Neumann, Anke Krug, Sven Foth, Udo Meinecke, Michael Lau, Mike Fabritius, Frank Jautzke (BWB-Ruhleben)

Margrit Preuss, Barbara Piotrowski, Diana Tzscheuschler (BWB-Labor Ruhleben)

Anton Peter-Fröhlich, Carsten Lüdicke, Oliver Hildebrandt (BWB-AE)

### *Veolia*

Annie Tazi-Pain (Veri)

### *Project partners*

Jens Leidhold, Martin Speier (VWS Deutschland GmbH, Krüger-Wabag)

Mirco Köhler (VWS Deutschland GmbH, Berkefeld)

Patrick Buchta (Inge AG)

### *TU Berlin*

Prof. Martin Jekel

Cornelia Genz, Geert Aschermann, Jutta Jakobs, Kathrin Noack, Angelina Patel, Anke Putschew, Martin Schulz, Yuki Sorgler, Julia Sturm

Last but not least

### *Oxeram project team (KWB)*

Ulf Miehe, Boris Lesjean, Morgane Boulestreau, Margarethe Langer, Christian Remy, Florian Kambach, Vincent Louvel, Christian Hattke, Francois Vuong, Robert Stein, Gregoire Nimeskern, Agnieszka Bodnar, Dorian Amon, Johanna Ludwig, Gudrun von der Waydrink, Alexander Schreck, Simon Kuhnt, Jan Schütz



## Table of Contents

Colophon.....	ii
Abstract (English).....	iii
Abstract (German).....	iv
Acknowledgements .....	vi
Chapter 1 Introduction.....	1
1.1 Goals of tertiary treatment – frame of OXERAM .....	1
1.2 Membrane filtration for tertiary treatment – drawbacks and advantages.....	1
1.3 Fouling and fouling control.....	2
1.3.1 Coagulation .....	2
1.3.2 Ozonation.....	3
Chapter 2 Material and Methods .....	5
2.1 Analysis .....	5
2.1.1 Sampling .....	5
2.1.2 BWB laboratory .....	5
2.1.3 On-site measurements .....	5
2.1.4 LC-OCD .....	6
2.1.5 Online.....	6
2.2 Pilot plants .....	6
2.2.1 Polymeric membrane pilot plant .....	8
2.2.2 Ceramic membrane pilot plant.....	10
2.2.3 Ozonation pilot plant.....	12
2.3 Membrane cleaning .....	14
2.3.1 Cleaning methods .....	14
2.4 Key figures for membrane filtration in pilot scale testing.....	15
2.4.1 Resistance and fouling rate .....	15
2.4.2 Permeability constraint during trial phase 1 .....	18
2.4.3 Membrane regeneration .....	18
2.5 Statistical trial planning .....	19
2.5.1 Why statistical trial planning? .....	19
2.5.2 Approach – Objective screening.....	19
2.5.3 Experimental design.....	21
Chapter 3 Results and discussion .....	22
3.1 Water quality.....	24
3.1.1 Phosphorus .....	25
3.1.2 Total Suspended Solids (TSS) .....	26

3.1.3 Chemical Oxygen Demand (COD) .....	29
3.1.4 Dissolved Organic Carbon (DOC) .....	30
3.1.5 UV absorbance @254 nm .....	32
3.1.6 LC-OCD .....	36
3.1.7 Eco-toxicity .....	41
3.2 Polymeric membrane operation .....	41
3.2.1 Module comparison .....	42
3.2.2 Results Statistical trial planning .....	44
3.2.3 Cleaning strategy .....	47
3.2.4 Economic evaluation of operation strategy – polymeric membranes .....	50
3.2.5 Trial phase 2: Long term operation (coagulant comparison) .....	51
3.2.6 Variable flux trial .....	53
3.2.7 Operation with ozone .....	54
3.3 Ceramic membrane operation .....	58
3.3.1 Trial phase 1 .....	58
3.3.2 Cleaning strategy .....	63
3.3.3 Long term demonstration .....	63
3.3.4 Economical trade off .....	64
Chapter 4 Conclusion .....	66
4.1 Proposed operation .....	66
4.1.1 Polymeric membrane .....	67
4.1.2 Ceramic membrane .....	67
4.2 Recommendation: How to use statistical trial planning in pilot scale .....	68
4.3 Ozonation and membrane filtration – What have we learned? .....	69
Bibliography .....	70
Appendix .....	72

## List of Figures

Figure 1: Flux enhancing effects of ozonation – possible mechanisms .....	4
Figure 2: Basic flow sheet.....	7
Figure 3: Basic flow sheet polymeric membrane pilot (without ozonation).....	8
Figure 4: Basic flow sheet ceramic membrane pilot .....	10
Figure 5: Tested ceramic membrane module by Metawater (©Metawater, 2011) .....	11
Figure 6: Ozone generator and bubble column .....	13
Figure 7: Basic flow sheet – Ozonation unit .....	13
Figure 8: Explanation of resistances and fouling rates .....	17
Figure 9: Theoretical TMP evolution for three different fouling rates .....	17
Figure 10: Experimental cube for a 23-region .....	21
Figure 11: Trial phases .....	23
Figure 12: Example of Whisker-Box-Plot .....	24
Figure 13: Total phosphorus and ortho-phosphate feed concentration.....	25
Figure 14: Total phosphorus concentration in filtrate – ceramic and polymeric membrane .....	26
Figure 15: Feed TSS concentration .....	27
Figure 16: TSS measurements UF2a.....	28
Figure 17: Chemical Oxygen Demand – feed and filtrate .....	29
Figure 18: COD removal correlated to the ozone and coagulant dosage (ceramic membrane) .....	30
Figure 19: DOC concentration – Feed .....	31
Figure 20: DOC - Feed & filtrate - Impact of coagulant concentration (without O <sub>3</sub> ) ....	31
Figure 21: DOC - Feed & filtrate - Impact of ozone dose.....	32
Figure 22: UV absorbance – Feed .....	32
Figure 23: UV absorbance - Feed & filtrate - Impact of coagulant concentration .....	33
Figure 24: UV absorbance – Feed & filtrate – Impact of ozone dose.....	33
Figure 25: Specific UV absorbance in the feed .....	34
Figure 26: Specific UV absorbance – Feed & filtrate – impact of coagulant concentration .....	35
Figure 27: Specific UV absorbance – Feed & filtrate – impact of ozone dose .....	36
Figure 28: LC-OCD chromatogram - WWTP Ruhleben secondary effluent.....	37
Figure 29: Biopolymer concentration in the feed .....	37
Figure 30: Biopolymer peak in relation to treatment (ceramic membrane filtrate) .....	38
Figure 31: Biopolymer reduction by pre-treatment .....	39
Figure 32: Biopolymer reduction – coagulant comparison.....	40

Figure 33: Biopolymer reduction – coagulant comparison with ozonation (6 – 7.2 mgO <sub>3</sub> /L) .....	40
Figure 34: Total fouling resistance 2nd module comparison campaign .....	43
Figure 35: Results statistical trial planning polymeric membranes – Total fouling rate prediction.....	46
Figure 36: CEB validation – without CEB.....	48
Figure 37: CEB validation – daily CEB.....	49
Figure 38: Economic comparison of operation strategy – polymeric membranes.....	51
Figure 39: Long term demonstration - Fe as coagulant.....	52
Figure 40: Long term demonstration - Al as coagulant.....	52
Figure 41: Total fouling resistance - variable flux trials .....	53
Figure 42: Operation with and without ozone – PES ultrafiltration; Al as coagulant ...	55
Figure 43: Fouling resistance and fouling rate with and without ozone – start ozone trials .....	56
Figure 44: Fouling resistance after backwash - end of ozone trials.....	57
Figure 45: Total fouling rates ceramic membrane - trial phase 1.....	59
Figure 46: Dissolved ozone concentration along water path.....	60
Figure 47: High flux experiments with 7.5 and 15 mgO <sub>3</sub> /L.....	61
Figure 48: Graphical interpretation of critical flux experiments.....	62
Figure 49: Long term operation with 90 and 120 L/(m <sup>2</sup> h) – Ceramic membrane.....	64
Figure 50: Economic trade off ceramic membrane.....	65
Figure 51: Plant design constraints.....	66

## List of Tables

Table 1: Online measurements devices .....	6
Table 2: Polymeric membrane specifications .....	9
Table 3: Specification of ceramic membrane module (Metawater) .....	11
Table 4: Measurement devices ozonation unit .....	13
Table 5: Clean water permeability and correspondent membrane resistance .....	16
Table 6: Evaluation of cleaning methods .....	19
Table 7: Controllable factors for both membrane types .....	20
Table 8: Notation of modules tested – polymeric membranes .....	22
Table 9: Water quality overview .....	24
Table 10: Total phosphorus concentration in the filtrate – Impact of ozonation (ceramic membrane) .....	26
Table 11: Module comparison - Total fouling rates.....	43
Table 12: CIP frequency in relation to the fouling rate – according to results of the statistical trial plan .....	47
Table 13: CEB validation .....	47
Table 14: Long term validation – operational set up.....	51
Table 15: Key parameter for different flux strategies .....	53
Table 16: Full scale design with constant/variable flux operation - dry weather peak flow 4.5 m <sup>3</sup> /s .....	54
Table 17: Mean trans-membrane pressures with and without ozone – treatment line 2 (UF2b) .....	57
Table 18: Results critical flux experiments .....	62
Table 19: Proposed operation polymeric membranes – Tertiary treatment WWTP Ruhleben .....	67
Table 20: Proposed operation ceramic membranes – Tertiary treatment WWTP Ruhleben .....	68
Table 21: Work sheet Polymeric Membrane (UF2) - Statistical Trial Planning.....	72
Table 22: Work sheet Ceramic Membrane - Statistical Trial Planning .....	72
Table 23: Coefficient table of fouling rate model: Trial phase1 UF2 .....	73

## List of Abbreviations

C	carbon
Ca	calcium
DOC	dissolved organic carbon
Fe	iron
FeCl <sub>3</sub>	iron(III) trichloride
KCl	potassium chloride
LC	liquid chromatography
L/(m <sup>2</sup> h)	liter per square meter per hour
MW	molecular weight
MWCO	molecular weight cutoff
N	nitrogen
Na	sodium
NaCl	sodium chloride
NaOH	sodium hydroxide
NTU	nephelometric turbidity unit
OCD	organic carbon detection
OND	organic nitrogen detection
PES	polyethersulfone
PVDF	polyvinylidene fluoride
R <sup>2</sup>	coefficient of determination
rpm	revolutions per minute
SEC	size exclusion chromatography
SI	international system of units
SP	sampling point
TDW	treated domestic wastewater
TMP	trans-membrane pressure
TOC	total organic carbon
UV	ultraviolet
WWTP	wastewater treatment plant

### Latin symbols

$A$	area	[m <sup>2</sup> ]
$c$	concentration	[mg · L <sup>-1</sup> ]
$c_i$	concentration in entity $i$	[kg · m <sup>-3</sup> ]
$c_{\text{feed}}$	concentration in feed	[mg · L <sup>-1</sup> ]
$c_{\text{perm}}$	concentration in permeate	[mg · L <sup>-1</sup> ]
$\eta$	dynamic viscosity	[N · s · m <sup>-2</sup> ]
$J$	flux	[m · s <sup>-1</sup> ]
$J_0$	pure water flux	[m · s <sup>-1</sup> ]
$m$	mass	[kg]
$m_i$	mass in entity $i$	[kg]
$M$	molecular weight, equivalent to Da (dalton)	[g · mol <sup>-1</sup> ]
$p$	pressure, also given in bar [10 <sup>5</sup> · N · m <sup>-2</sup> ]	[N · m <sup>-2</sup> ]
$R$	resistance	[m <sup>-1</sup> ]
$R_m$	resistance by membrane	[m <sup>-1</sup> ]
$R_{\text{f,rev}}$	resistance by reversible fouling	[m <sup>-1</sup> ]
$R_{\text{f,irr}}$	resistance by irreversible fouling	[m <sup>-1</sup> ]
$T$	temperature	[°C]
$T_M$	measured temperature	[°C]
$V$	volume	[L]
$V_i$	volume of entity $i$	[m <sup>3</sup> ]

# Chapter 1

## Introduction

### 1.1 Goals of tertiary treatment – frame of OXERAM

The European Water Framework Directive demands activities targeting the reinstatement of a natural good water quality of all water bodies (EC 2000). These activities need to be carried out throughout the whole water cycle. Since the wastewater treatment plants (WWTP) discharge the treated wastewater into surface waters the possibilities and limitation to increase the water quality by implementation of a tertiary treatment step are addressed within OXERAM. For the case of Berlin, tertiary treatment focuses on further reduction of the phosphorus load. In addition, disinfection is required in order to achieve “good bathing water quality”. The project OXERAM compares different technologies suitable for tertiary treatment with regard to ecological benefits and economic feasibility. In this report the outcomes of the membrane trials are presented. The results of the working packages addressing Microsieves, Life Cycle Analysis, Online Monitoring and Lab scale investigation can be found here: <http://www.kompetenz-wasser.de>.

### 1.2 Membrane filtration for tertiary treatment – drawbacks and advantages

Filtration with micro- or ultrafiltration membrane assures highest filtrate qualities because of the clearly defined cut-off. Due to cake layer formation and in pore blocking the cut-off achieved in reality can even be lower than the nominal pore size. Total Suspended Solids (TSS) are retained completely by membrane filtration and disinfection according to the European bathing water guideline is achieved (EC 2000). Also phosphorus is retained down to the dissolved fraction and pre-treatment with coagulation increases the removal even further. Because of these benefits and the possibility to combine membrane technology with further advanced wastewater treatment technologies, such as ozonation or powder activated carbon (PAC), membranes technology could be a comprehensive solution for wastewater treatment. One of the major cost positions is the investment and replacement costs for the membranes themselves. Therefore an accurate estimation of the sustainable design flux is the key criteria when designing a membrane stage. The driving force to push water through the membrane pores is in most cases provided by electrically powered pumps. This additional energy is necessary and adds up to the overall energy consumption of the wastewater treatment. The head loss caused by the membrane itself is a physical feature that cannot be avoided. The additional head loss caused by membrane fouling increases the energy demand. Pre-treatment, e.g. coagulation or ozonation, and a cleaning strategy optimized for the water quality are necessary to minimize these negative impacts. The cleaning strategy includes regular cleaning with chemical enhanced backwash (CEB) and cleaning in place (CIP), see section 2.3.

Membrane systems as tertiary treatment processes are implemented in an existing WWTP with a conventional activated sludge (CAS) regime after the clarifier, which was designed for a definite maximum flow. This design flow represents another constraint for a downstream membrane process: The return flow of backwash and cleaning water must not exceed tolerable amounts, because of the activated sludge basins and the secondary clarifiers. Higher flows result in insufficient nutrient removal due to the

overload of the biological basins and/or low contact times. Additionally sludge loss in the secondary clarifier may occur. A maximum return flow of 5 % of the treated water was defined by the operator Berliner Wasserbetriebe (BWB) for the WWTP Ruhleben. In case of a recovery rate < 95 % a second filtration unit treating the backwash water can therefore be necessary, which requires further investment.

### **1.3 Fouling and fouling control**

Fouling of membranes and the question of the responsible water constituents has been a topic in research for more than two decades and there are several publications with different outcomes. This inconsistency emphasizes the complex nature of membrane fouling. Most references have in common that the so called DOC-fraction of biopolymers plays a major role in fouling (Zheng et al. 2009, De la Torre et al. 2009, Te Poele 2006, and Haberkamp et al. 2008). Proteins and polysaccharides are the major fraction of these biopolymers, but the exact compounds, ratio, origin, and characteristics are still unknown (Amy 2009). Pre-treatment steps are implemented in order to limit the fouling potential and reduce the amount of free biopolymers reaching the membrane surface.

In order to minimize fouling different operational strategies are applied and process optimization has to be done according to the water quality. The following sections describe the pre-treatment steps tested within OXERAM.

#### **1.3.1 Coagulation**

Coagulation in water treatment is used for phosphorus removal amongst others. Within the various wastewater treatment schemes there are several options how to apply coagulation (location of dosage, mixing system, retention time, type of coagulant etc.). In membrane technology coagulation does fulfil three tasks:

- Precipitation of dissolved phosphorus
- Binding of foulants (high molecular fractions of DOC)
- Cake layer formation with the above mentioned solids

The coagulant dosage is one of the cost drivers in membrane processes, due to the purchase costs as well as the disposal costs. At the same time coagulation controls the trans-membrane pressure, therefore the required pumping energy as well as the needs for backwash and/or chemical cleanings. Theoretically a trade-off can be defined, where the membrane filtration is operated in a financially optimised way.

Coagulation is widely used for tertiary treatment processes as well as for drinking water production (Haberkamp et al. 2007, Kim et al. 2005). The goal of coagulation in membrane filtration technologies is to form solid particles that can be retained by the membrane and entrap the colloids, major membrane foulants. Cake layer formation also functions as an additional filtration barrier. Therefore coagulation reduces the amount of biopolymers reaching the membrane surface, thus lowering the fouling propensity. At the same time, dissolved phosphorus compounds are precipitated and removed by the filtration step. Since phosphorus removal is one of the main goals of tertiary treatment, there is a synergy of coagulation: Fouling control and enhanced phosphorus removal.



### 1.3.2 Ozonation

Ozonation as an additional pre-treatment step has been studied recently and higher fluxes could be maintained with ceramic membranes (Lehman and Liu 2009, Panglisch et al. 2010). Remarkably high fluxes ( $>500 \text{ L}/(\text{m}^2\text{h})$ ) were achieved treating surface waters for drinking water production. Genz et al. 2011 reported on the positive impact of ozonation on filterability of secondary effluent using a UF polymeric membrane and attributed the beneficial effect of ozonation to the reduction, transformation, and change of biopolymer characteristics. Van Geluwe et al. 2011 summarized the outcomes of several studies about ozonation and membrane fouling paying special attention to the effect of ozone and OH-radicals on natural organic matter (NOM) in the treated water. Increase of filterability has been reported in several studies using different waters including secondary effluent (Wang et al. 2007). Comparing different pre-treatment technologies for secondary effluent prior ultrafiltration, Filloux et al. 2012 showed the effect of pre-ozonation on the biopolymer fraction of the effluent organic matter (EfOM) and the positive effect on the filtration performance. The applied specific ozone dose of  $5.5 \text{ mgO}_3/\text{mgC}$  was relatively high in order to be able to see a significant impact of the ozonation step.

The following three effects are supposedly the reason for the increased filterability:

1. The microfloculation effect, which describes the enhanced flocculation due to ozonation, forming more stable flocs
2. Transformation / oxidation of biopolymers to smaller compounds passing the membrane
3. Permanent cleaning through dissolved ozone reaching the membrane surface where residual ozone is present after reaction (higher  $\text{O}_3$  doses)

These effects will be investigated within OXERAM and the results will be used in order to weight the interacting effects.

Dissolved ozone can only be applied when ozone resistant membrane materials are used, e.g.  $\text{Al}_2\text{O}_3$  or PVDF. The same constraint applies for the used potting and piping system. Within OXERAM the ceramic membrane pilot is designed to test dissolved ozone reaching the membrane surface. This requires a short retention time between the ozonation unit and the membrane pilot and an appropriate safety set up, e.g. ambient air measurement.

Boulestreau and Miehe 2010 summarized the experiences with the combination of ozonation and membrane filtration reported in literature (link: [Review on coagulation and ozonation \(www.kompetenz-wasser.de\)](http://www.kompetenz-wasser.de)).

The beneficial effect on filterability has been published using lab scale equipment and an ultrafiltration membrane made of polyethersulfonate (PES) (Genz et al. 2011). The feasibility combining ozonation and organic membranes was tested in pilot scale for the first time within OXERAM.

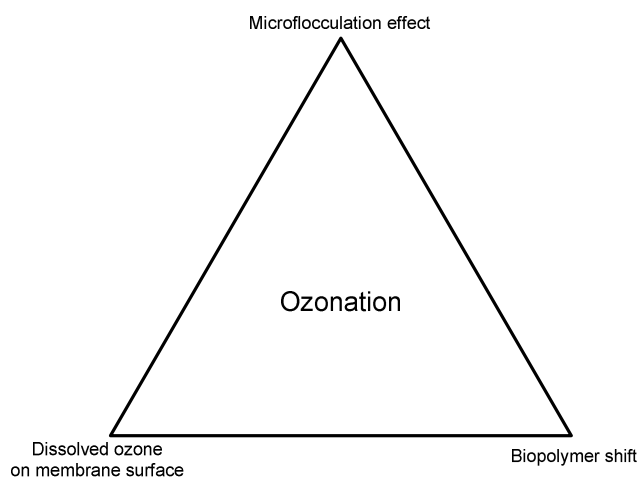

**Figure 1: Flux enhancing effects of ozonation – possible mechanisms**

In order to optimize the proposed combined process, a classification of the discussed effects is required. Since ozone production demands high energy input, optimization focuses on the necessary ozone dose.

The combination of ozonation and non-ozone resistant membrane materials requires special care to control the possibility of dissolved ozone reaching the membrane surface, see section 3.2.6.

## Chapter 2

### Material and Methods

Evaluation of a new technology includes manifold parameters, such as laboratory analysis and operational parameters as well as global factors considering the implementation in full scale applications. The latter evaluation for the technologies tested within the OXERAM project was carried out by Dr. Christian Remy by life cycle analysis (LCA) and life cycle costing (LCC). This report can be found here: <http://www.kompetenz-wasser.de>.

Water quality parameters were measured on-site (trial laboratory), at the laboratory of Berliner Wasser Betriebe (BWB) and at TU Berlin, Chair of Water Quality Control. The applied analysis techniques are explained in the following section 2.1. The sections afterwards describe in detail the membrane and the ozonation pilot plants. The subsequent section describes the cleaning methods for all membrane types, because the same measures targeting the same outcome were applied. In order to make best use of the experimental time given statistical trial planning was applied for the first trial phase. This approach is explained in detail in section 2.5.

#### 2.1 Analysis

##### 2.1.1 Sampling

Sampling was carried out as 24 h mix samples for the influent during the first phase of the experiments and as grab samples for the filtrate. The 24 h mix samples were collected time proportional (250 ml every 15 min.) and collected in one container which was mixed before analysis.

During the later test phases grab samples were collected and analyzed twice a week.

##### 2.1.2 BWB laboratory

The following standard analyses were carried out by the accredited laboratory of Berliner Wasser Betriebe at WWTP Ruhleben according to the mentioned guidelines:

Chemical Oxygen Demand (COD)	DIN ISO 15705
Dissolved Organic Carbon (DOC)	DIN EN 1484 (pre-filtered with 0.45 µm)
Ferric	DIN EN ISO 11885
Total phosphorous (TP)	DIN EN ISO 11885
Total Suspended Solids	DIN EN 872

##### 2.1.3 On-site measurements

Rapid tests using Dr. Lange cuvette tests (e.g. PO<sub>4</sub>-P, COD, etc.) were done as complementary measurements in order to increase the reactivity and flexibility in the trials' program. Therefore new ways of operation could be evaluated easily. Ortho-phosphate was only measured on-site applying the LCS 349 cuvette [0.01 – 0.5 mgP/L] test minimizing possible sources of errors, e.g. storage or filtration. The on-site laboratory assured a quick evaluation of the current performance.

### 2.1.4 LC-OCD

All LC-OCD measurements were carried out by Manuel Godehardt and his colleagues at TU Berlin, Chair of Water Quality Control.

The system, obtained from DOC Labor Dr. Huber (Germany) includes a liquid chromatograph (LC) with size exclusion chromatography (SEC, HW555, Alltech-GROM GmbH, Germany), followed by a detector for UVA 254 (Smartline UV Detector 200, Knauer, Germany) and a Grätzel thin-film reactor for DOC oxidation, with a subsequent infrared detector for carbon dioxide (Ultramat 6, Siemens, Germany). Samples were filtered with 0.45 µm cellulose-acetate filters before analysis. LC-OCD results were evaluated as explained by Huber et al. 2011.

### 2.1.5 Online

Online measurement devices are applied in process technology and implemented in control strategies. Therefore a robust and reliable technology is required in order to protect the equipment and to assure the product quality.

Turbidity, pH and temperature were included in the pilot plant set up and recorded in 3 s interval. Table 1 shows the measurement devices installed in the two pilot plants.

**Table 1: Online measurements devices**

	<b>Turbidity</b>	<b>pH</b>	<b>Temperature</b>
Polymeric membrane pilot	Endress &Hauser Turbimax W CUS31	Endress &Hauser Liquisys M CPM 253 MR0105	Endress &Hauser Liquisys M CPM 253 MR0105
Ceramic membrane pilot	Endress &Hauser Turbimax W CUS31	Grundfoss	Pt100 resistance thermometer
Ozonation pilot (see Table 4)	Ozone concentration in product gas Ozone concentration in off gas Dissolved ozone: Hach-Lange Orbisphere		

## 2.2 Pilot plants

The combination of the discussed pre-treatments in pilot scale required a precise global plant management, in order to use the given set up efficiently. The ozonation plant was designed with a single treatment line and both membrane pilots were connected to a distribution tank. Figure 2 shows a schematic set up of the pilot plants at the WWTP Ruhleben.

The system was designed to be able to run all three (polymeric + ceramic + ozonation) pilot plants independently as well as to feed both membrane pilots with ozonized water. The set-up also allowed running one membrane pilot with ozonized while the other was operated with non-ozonized water. Since coagulation is a necessary treatment step prior membrane filtration when DOC-rich water is fed, this treatment step was included by the plant manufacturer within their pilots, see section 2.2.1 and 2.2.2.

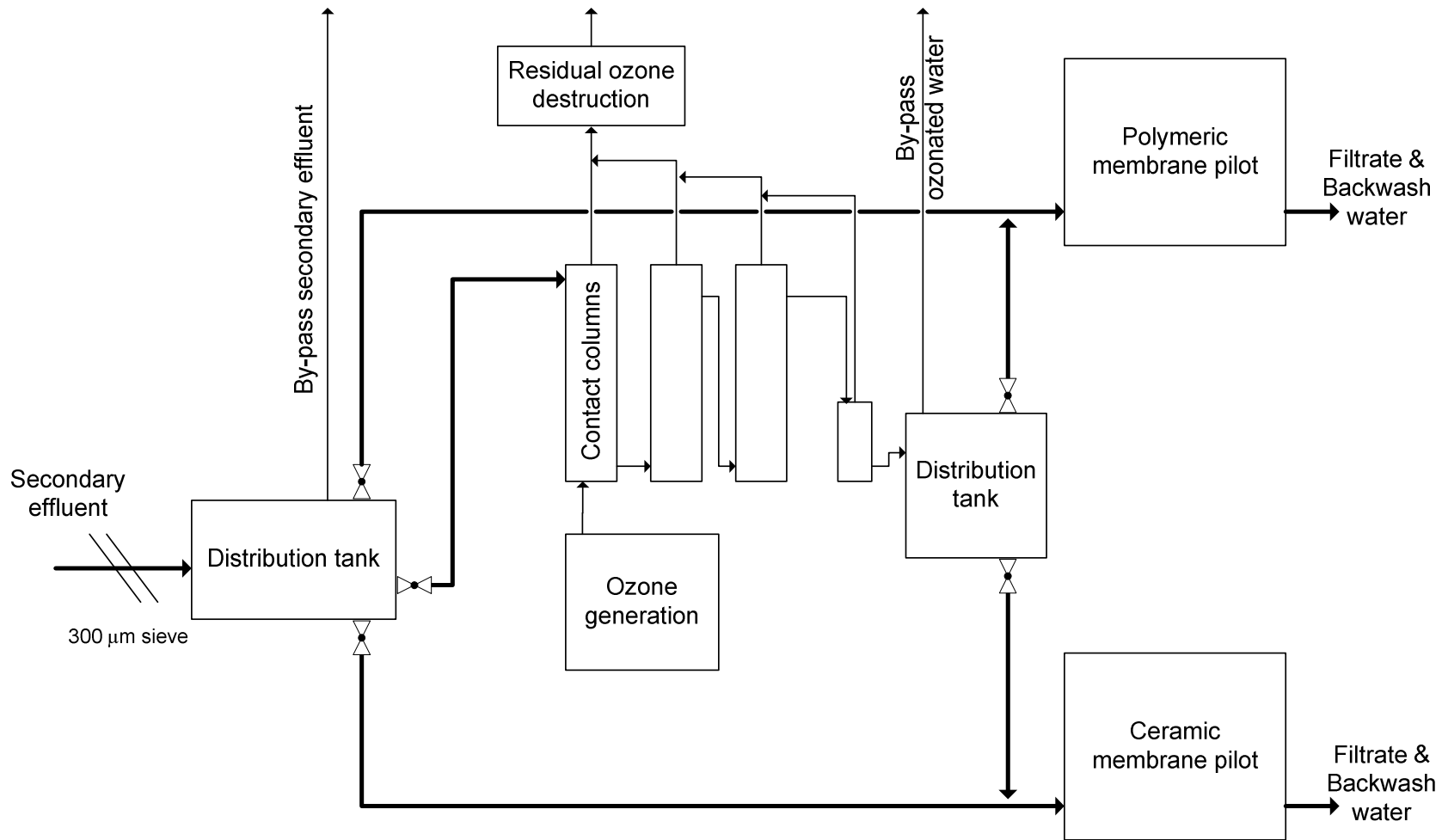

Figure 2: Basic flow sheet

Experiments with high ozone doses creating dissolved ozone were planned for the ceramic membrane in order to evaluate the impact of dissolved ozone on the membrane surface. Dissolved ozone reacts quickly with the water constituents and potential biofilm formed within the piping system, therefore a low retention time between the ozonation step and the ceramic membrane pilot was necessary. In contrast to this constraint was the need to protect the polymeric membrane. A high load of dissolved ozone destroys the polymeric membrane material and even though the resistance capacity is unknown precautionary steps have to be implemented avoiding membrane breakage. The measures to assure both needs are described in section 2.2.3.

### 2.2.1 Polymeric membrane pilot plant

The polymeric membrane pilot was installed within a 20' freight container and constructed by VWS Krüger-Wabag. Two modules could be operated in parallel. Both modules were operated independently from each other. This set up gave the opportunity to compare two modules with different capillary diameters and therefore different membrane surfaces installed in the same module housing. This comparison was carried out in the first trial phase and repeated a second time later on. In the last trial phase two modules of the same type were installed and operated exactly the same way except for the coagulant.

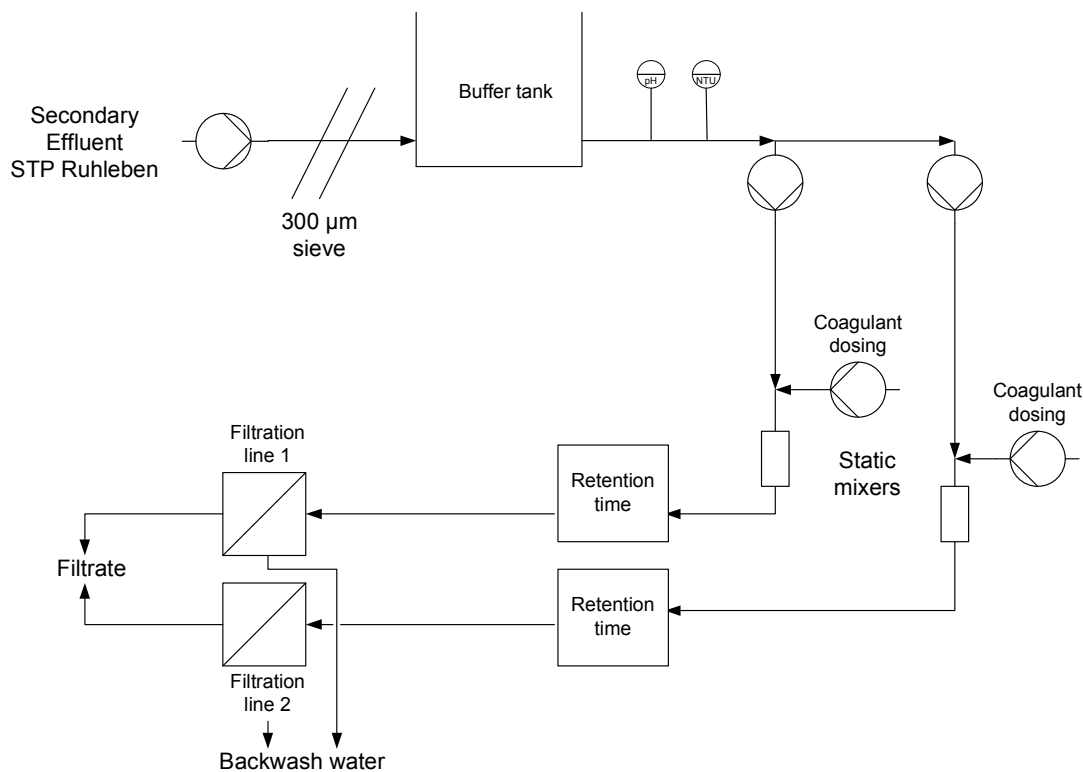

Figure 3: Basic flow sheet polymeric membrane pilot (without ozonation)

### 2.2.1.1 Membrane modules

As mentioned above the pilot plant was equipped with two independent operating lines. The following two module types supplied by Inge GmbH were tested in different experimental phases:

**Table 2: Polymeric membrane specifications**

	Unit	Modules	
<b>Product name</b>		Dizzer® XL 1.5 MB 40 W	Dizzer® XL 0.9 MB 60 W
<b>Operation mode</b>		In/Out filtration	
<b>Membrane surface</b>	m <sup>2</sup>	40	60
<b>Capillary diameter (ID)</b>	mm	1.5	0.9
<b>Pore size</b>	µm	0.02 ultrafiltration	
<b>Capillaries per fiber</b>		7	
<b>Material</b>		Polyethersulfon (PES)	
<b>Pressure</b>	bar	max. 5	
<b>Temperature</b>	°C	0 – 40	
<b>Cleaning and Disinfection Chemicals</b>			
<b>Active Chlorine</b>	ppm ppmh	max. 200 max. 200.000	
<b>Hydrogen peroxide H<sub>2</sub>O<sub>2</sub></b>	ppm	max. 500	
<b>Base</b>	pH	max. 13	
<b>Acid</b>	pH	min. 1	
<b>Surface load</b>			
<b>Filtration</b>	L/(m <sup>2</sup> h)	60 – 180	
<b>Backwashing</b>	L/(m <sup>2</sup> h)	230 – 250	
<b>Transmembrane Pressure (TMP)</b>			
<b>Filtration</b>	bar	0 – 1.5	
<b>Backwash</b>	bar	0 – 3.0	

The module with the smaller capillary diameter is designed for drinking water production and the feasibility for this module to be used in wastewater treatment was tested with clean effluent of WWTP Ruhleben (TS < 10 mg/L). The advantage of this module is the installed membrane surface within an identical housing at similar module costs.

### 2.2.1.2 Coagulation

A static mixer (U&A process technology) was used to assure a sufficient rapid mixing of the coagulant with the water stream. The G-value was in the range of 6000 – 20000 s<sup>-1</sup> depending on the applied flow. The retention time before filtration was kept above 45 s (45 – 135 s) for all experiments. Three different pipe loops were available providing the

opportunity to change the pipe volume and thus keeping the retention time constant at varying flows.

### 2.2.1.3 Control program and data evaluation

The polymeric pilot plant was equipped with the control and visualization software FIS#<sup>®</sup> by Hermos. The raw data was stored in 3 s intervals archived in a single file each day. With these data the key figures mentioned later on can be calculated.

### 2.2.2 Ceramic membrane pilot plant

The pilot plant was fully automated and the values for flux, coagulant dosage, time of filtration, and ozone dose were defined for each trial run, e.g. 60 L/(m<sup>2</sup>h), 8 mgFe/L, 30 minutes of filtration, and 15 mgO<sub>3</sub>/L. The pilot was constructed by VWS Berkefeld.

A basic flow sheet is shown in Figure 4.

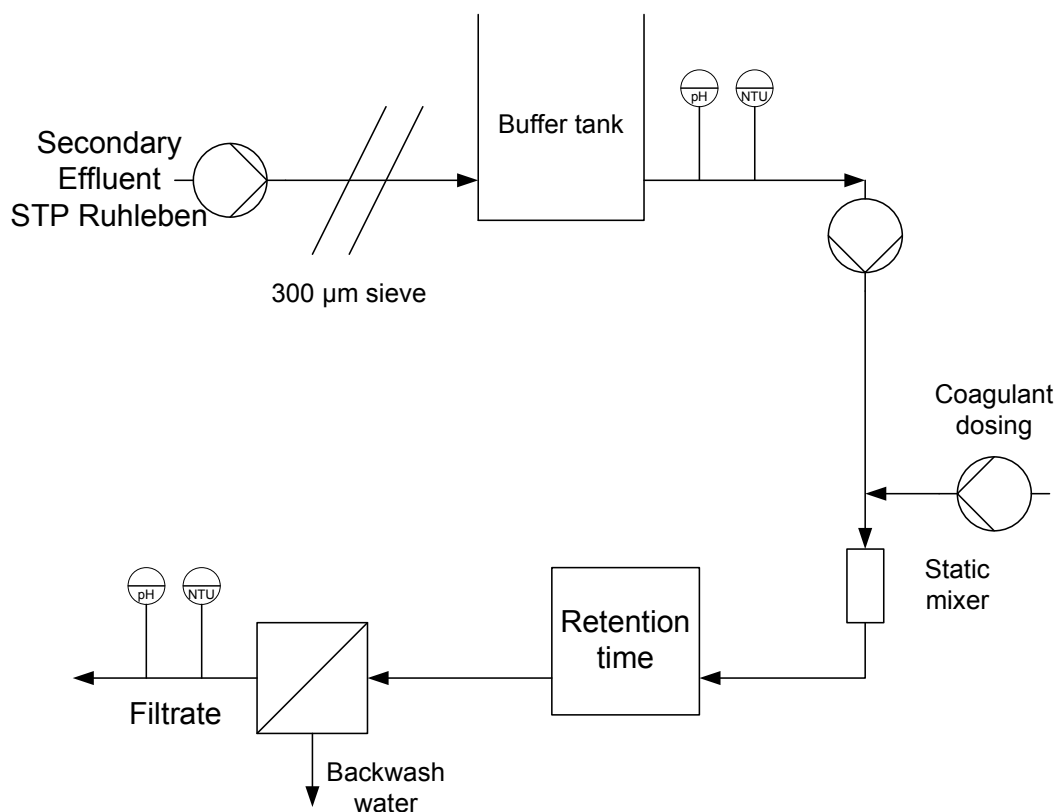

**Figure 4: Basic flow sheet ceramic membrane pilot**

Online measurements, e.g. turbidity, pH, trans-membrane pressure (TMP), were used for evaluation of the different pre-treatments and operational set ups. Low amounts of backwash water due to high pressure backwash led to recovery rates greater than 95 %.

The backwash regime requires a different technical set up compared to the polymeric membrane pilot. A compressor station providing pressured air with 5 bar and a pressure tank serving as a reservoir for backwash and chemical enhanced backwash are necessary. The backwash effect relies on a quick opening of the valves to ensure a high impulse through the membrane. This quick opening has to be kept in mind when designing the piping system and the valves. In the pilot plant valves driven by pressured air were installed.



### 2.2.2.1 Membrane module

The ceramic membrane module was manufactured by the Japanese company Metawater and is with 25 m<sup>2</sup> the largest monolithic ceramic membrane module commercially available. The module is made of Al<sub>2</sub>O<sub>3</sub> and considering only the membrane itself there no restrictions for temperature and pH. But due to the rubber sealing made of EPDM the manufacturer allows only pH values between 2 and 10.

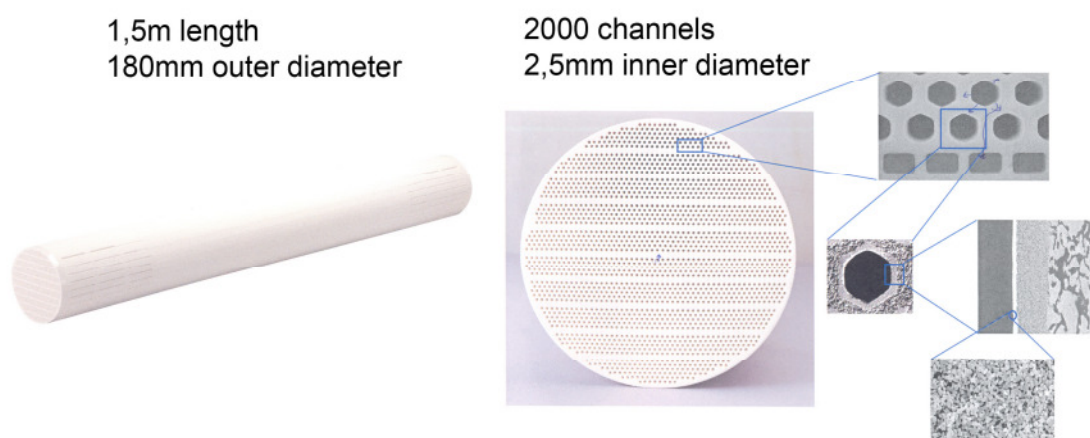

Figure 5: Tested ceramic membrane module by Metawater (©Metawater, 2011)

Table 3: Specification of ceramic membrane module (Metawater)

	Unit	Module
<b>Product</b>		3 <sup>rd</sup> generation
<b>Operation mode</b>		In/Out filtration
<b>Membrane surface</b>	m <sup>2</sup>	25
<b>Capillary diameter (ID)</b>	mm	2.5
<b>Pore size</b>	µm	0.1
<b>Channels</b>		2000
<b>Material</b>		Al <sub>2</sub> O <sub>3</sub>
<b>Pressure</b>	bar	max. 5
<b>Cleaning and Disinfection Chemicals</b>		
<b>Active Chlorine</b>	ppm	max. 3000
<b>Base</b>	pH	max. 10
<b>Acid</b>	pH	min. 2
<b>Surface load</b>		
<b>Filtration</b>	L/(m <sup>2</sup> h)	0 - 500
<b>Transmembrane Pressure (TMP)</b>		
<b>Filtration</b>	bar	0 – 3
<b>Backwash</b>	bar	0 – 5 (pressured air)

### 2.2.2.2 Control program and data evaluation

As in the polymeric membrane pilot the data was recorded every 3 s and archived on a daily basis. The same key figures were calculated and evaluated.

### 2.2.2.3 Coagulation

A static mixer (U&A process technology) was used to assure a sufficient rapid mixing of the coagulant with the water stream. The G-value was in the range of 5000 – 15000 s<sup>-1</sup> depending on the applied flow. The retention time before filtration was kept above 45 s for all experiments. Three different pipe loops were available providing the opportunity to change the pipe volume and thus keeping the retention time constant at varying flows.

## 2.2.3 Ozonation pilot plant

A bubble column with a counter-stream flow was used for mass transfer and reaction. The bubble column was 5 m high with a diameter of ~400 mm, thus a volume of ~630 L. The gas flow was held constant at 1 Nm<sup>3</sup>/h resulting in a superficial gas velocity of 0.002 m/s and a superficial liquid velocity of 0.01 m/s when applying 5 m<sup>3</sup>/h. The applied ozone dose was held constant either at 7.2 - 9 or at 15 mgO<sub>3</sub>/L. Equipped with ozone probes for inlet and outlet gas, the ozone mass balance was permanently recorded and controlled. The ozone dose  $d$  is defined as the ozone mass transferred into the water correlated to the water flow.

$$d = (c_{O_3, in} - c_{O_3, out}) * \frac{\dot{V}_{Gas}}{\dot{V}_{H_2O}}$$

where  $c_{O_3, in}$  is the ozone concentration in the inlet gas,  $c_{O_3, out}$  is the ozone concentration in the outlet gas,  $\dot{V}_{Gas}$  the gas flow, and  $\dot{V}_{H_2O}$  the water flow.

For further evaluation the ozone dose was correlated to the DOC, defined as the specific ozone dose  $z$ . As described before, the retention time between the ozonation step and the ceramic membrane should be held as short as possible when evaluating the cleaning effect of dissolved ozone on the membrane surface. The ozonation pilot gave the opportunity to reduce the retention time using a by-pass of the two last reaction columns. Several sampling points along the piping system enabled to record ozone profiles. These ozone profiles showed the expecting degrading trend of ozone in water streams.

During the trials feeding the polymeric membrane pilot the retention time within the ozonation step was increased by using all three columns. Additionally sodium-bisulfite was dosed into the water flow before the distribution tank. Sodium-bisulfite reacts quickly with ozone and does not have negative effect for the polymeric membranes, thus is an appropriate reactant.

### 2.2.3.1 Ozone generation and mass transfer

Ozone was produced on site using oxygen enriched air (~90 %) by a high potential generator (Xylem-WEDECO). The maximum capacity of the ozone generator was 100 gO<sub>3</sub>/h (GSO 30). The generator and the counter stream bubble column are shown in Figure 6. Two air separation units (AirSep® Corporation PSA Oxygen) Generator were installed producing the oxygen enriched air.



Figure 6: Ozone generator and bubble column

Only the first column was used for mass transfer and reaction, while the latter two columns were used for extended reaction/retention time and, e.g. for trials feeding ozonized water to the polymeric membranes. Figure 7 displays the basic flow sheet for the ozone contact unit.

Table 4: Measurement devices ozonation unit

	Device	Measurement range
Inlet gas	Wedeco HC-400plus	0 - 400 g/Nm <sup>3</sup>
Outlet gas	Wedeco MC-400plus	0 - 50 g/Nm <sup>3</sup>
Dissolved ozone	Hach-Lange Orbisphere	0 – 50 ppm

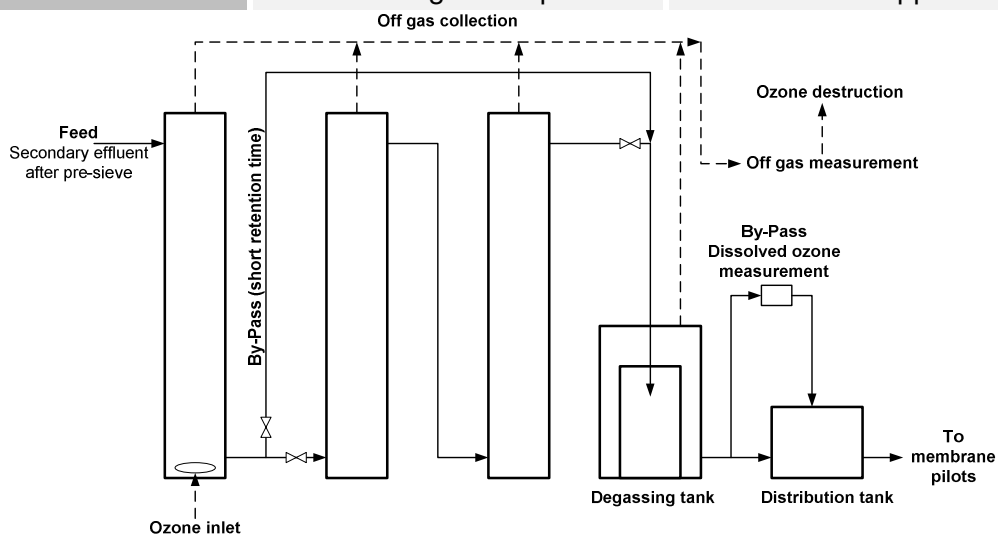

Figure 7: Basic flow sheet – Ozonation unit

## 2.3 Membrane cleaning

### 2.3.1 Cleaning methods

Three different cleaning methods were applied for the membrane pilot plants:

#### ***Backwash (BW)***

Polymeric membrane: The mechanical cleaning, namely backwash (BW), was carried out when either the set time of filtration exceeded or the defined maximum TMP of 0.8 bar was reached. Since the filtration mode was bottom fed, the backwash was first flushed out to the top and then to the bottom. The target backwash flux was 250 L/(m<sup>2</sup>h) (10 m<sup>3</sup>/h for the 40 m<sup>2</sup> module), thus each second of backwash cost about 2.8 L.

Ceramic membrane: A high pressure backwash can be applied at the ceramic membrane, due to the immense mechanical strength. Using pressured air, 50 liter of filtrate is flushed through membrane with 5 bar in the beginning. Afterwards a water-air mixture scrubs the raw water side membrane intensively.

#### ***Chemical Enhanced Backwash (CEB)***

Chemical enhanced backwash was possible using three different chemicals:

- Sulfuric acid (H<sub>2</sub>SO<sub>4</sub>)

Sulfuric acid cleans inorganic deposits originated either from the secondary effluent or from the pre-treatment, e.g. ferric or alum introduced as coagulant. The cleaning solution during our trials reached a pH-value below 2.

- Sodium hydroxide (NaOH)

Sodium hydroxide cleans organic foulants on the membrane surface and pores. Organic fouling is based on the adsorption of organic molecules on the membrane surfaces. It is relevant in membrane filtration with source water containing relatively high natural organic matter (NOM). The applied pH-value was above 12.

- Sodium hypochlorite (NaOCl)

Sodium hypochlorite cleans off biological fouling through the oxidizing power. Biofilm formation occurs almost on every surface in contact with water. With the nutrient supply in wastewater treatment biofilm formation is likely to appear. The operation in tertiary treatment with a high flux backwash washes off the biofilm on the membrane surface regularly in comparison to membrane filtration processes where a backwash is not or only with low pressure and/or flow possible e.g. membrane bioreactor (MBR) or reverse osmosis (RO) processes. Nevertheless, biofilm formation also occurs in tertiary treatment filtration and needs to be treated regularly. In our case we applied a concentration of 200 ppm of Cl during CEBs with NaOCl once a week.

Optimization included the frequency, duration, and combination of the used chemicals, see chapter 3.2.3.

#### ***Cleaning in place (CIP)***

A cleaning in place (CIP) is carried out when a membrane module is heavily fouled. The required CIP frequency has an impact on the capital and operational costs, since the membrane stacks are out of operation during a CIP and the cleaning is carried out in a semi-automatic way. A CIP usually takes 16 – 24 h, depending on the degree of fouling.

The chemical solution for CIPs was heated in order to increase the cleaning effect. During our trials the maximum temperature was 40 °C. The chemical solution is circulated through the raw water side and a small flow is filtered through the permeate side in order to clean and flush the pores. Circulating the cleaning solution shows an additional cleaning effect. Following detergents were used:

- Mem-X®

Sodium hydroxide based detergent with a mixture of tensides. This high efficient cleaning detergent is commercially available and can be used when the membrane is heavily fouled.

- Sulfuric acid (H<sub>2</sub>SO<sub>4</sub>)
- Citric acid (C<sub>6</sub>H<sub>8</sub>O<sub>7</sub>)

Citric acid is widely used for membrane cleaning due to the chelating effect. A concentration of 4 g/L citric acid was applied and the pH-value was further reduced below 2 with H<sub>2</sub>SO<sub>4</sub> or HCl.

- Sodium hypochlorite (NaOCl)

Using NaOCl for CIPs is required when bio-fouling has occurred. In this case the concentration can be increased according to the guideline of the membrane manufacturer.

The CIPs were carried out in three steps:

- |                  |  |       |
|------------------|--|-------|
| 1. Citric acid   | 2-3 h  | 40 °C |
| 2. MemX          | 12-16 h  | 40 °C |
|                  | Soaking over night; circulating and heating at the start and the end of this cleaning step |       |
| 3. Sulfuric acid | 2-3 h  | 40 °C |

Between each cleaning step the module was flushed with tap water and filtrate. The module was slowly cooled down to the tap water temperature in order to avoid temperature stress on the housing.

For the ceramic membrane the caustic cleaning step was only permitted up to a pH-value of 10. The second cleaning step was therefore carried out with NaOCl with a concentration of 3000 ppm Cl.

## 2.4 Key figures for membrane filtration in pilot scale testing

Before global parameters can be used for designing full scale treatment plants and an economical and environmental assessment is carried out, the precise description of the major factors for successful operation have to be evaluated critically. In the following sections the key figures used for the evaluation of the membrane filtration are given.

### 2.4.1 Resistance and fouling rate

The filtration resistance is expressed as:

$$R = \frac{\Delta p}{\eta * J}$$

where  $J$  is the flux in  $L/(m^2h)$ ,  $\eta$  is the dynamic viscosity of the feed in  $Ns/m^2$ ,  $\Delta p$  is the trans-membrane pressure in bar, and  $R$  is the filtration resistance in  $m^{-1}$ .

The resistance can be subdivided into different fractions:

- Membrane resistance  $R_M$  – The resistance caused by the clean membrane itself and the physical properties of the fluid
- Total fouling resistance  $R_F$  – The resistance caused by the water components and pre-treatment measures
- Hydraulic irreversible fouling resistance – The share of resistance, that cannot be flushed off by a hydraulic backwash

Since the  $R_M$  cannot be influenced with the existing set up the total fouling resistance  $R_F$  and the irreversible fouling resistance are shown in this report.

**Table 5: Clean water permeability and correspondent membrane resistance**

	<b>Ultrafiltration (PES 20 nm)</b>	<b>Microfiltration (Al<sub>2</sub>O<sub>3</sub> 100 nm)</b>
<b>Permeability@20° C</b>	~1,500 L/(m <sup>2</sup> hbar) (own measurements with potable water)	~1,280 L/(m <sup>2</sup> hbar) (Lehman and Liu 2009)
<b>Corresponding membrane resistance</b>	$2.4 \cdot 10^{11} m^{-1}$	$2.8 \cdot 10^{11} m^{-1}$

In order to estimate the cleaning needs the fouling rates were used. The fouling rate can be calculated with:

$$\frac{dR}{dt} = \frac{1}{dt} \frac{d\Delta p}{\eta * J}$$

Considering the temperature dependency of the viscosity, the viscosity at the current temperature was calculated using following empirical equation (Roorda et al. 2004, Haberkamp 2008, Zheng 2010):

$$\eta = \frac{0.497}{\sqrt{(T + 42.5)^3}}$$

where  $T$  is the temperature in °C.

Two different fouling rates were used for evaluation of the trials:

The **total fouling rate** is determined for the period of operation using the resistance at the beginning of the filtration and trial run and the resistance at the end of the filtration and trial run. This rate includes all resistances to be overcome during operation.

The **irreversible fouling rate** is determined using the resistance at the beginning of the filtration and trial run and the resistance at the beginning of the filtration cycle at the end of the trial run. Irreversible fouling cannot be cleaned off completely by hydraulic backwash or CEB. In order to evaluate the irreversible fouling, the TMP at the beginning of each filtration cycle was determined using the mean value for the first 2 minutes.

Figure 8 explains the different fractions of the filtration resistance and how the fouling rates are determined.

The hydraulic back flow must not exceed 5 % and a lot of investment costs can be saved when only one filtration step is necessary. The recovery rate can be calculated precisely as long as the TMP does not reach the defined maximum TMP. A shortened filtration cycle leads to lower recoveries.

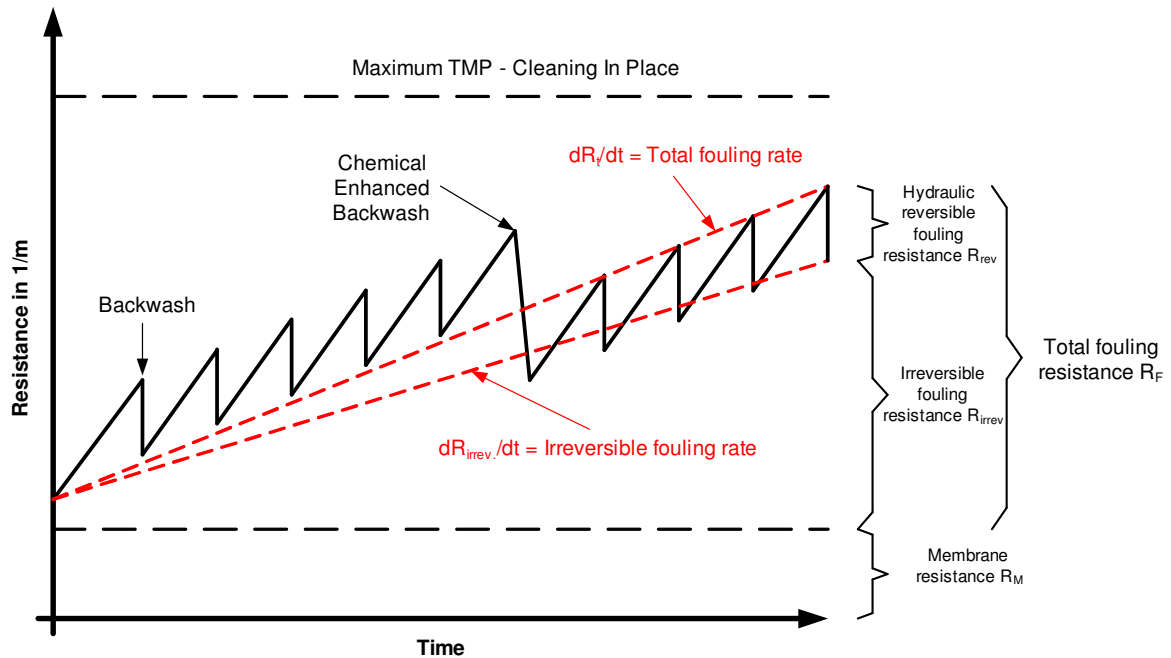

Figure 8: Explanation of resistances and fouling rates

The fouling rates give the decisive information about the process: The estimated CIP interval for given maximum TMP. In our case the maximum TMP was defined as 0.8 bar. This value is a compromise between operating and investment costs (Boulestreau and Miehe 2010). Figure 9 shows how the CIP interval was calculated with a given total fouling rate. Three fouling rates are exemplary given and when the maximum TMP is reached a CIP has to be carried out.

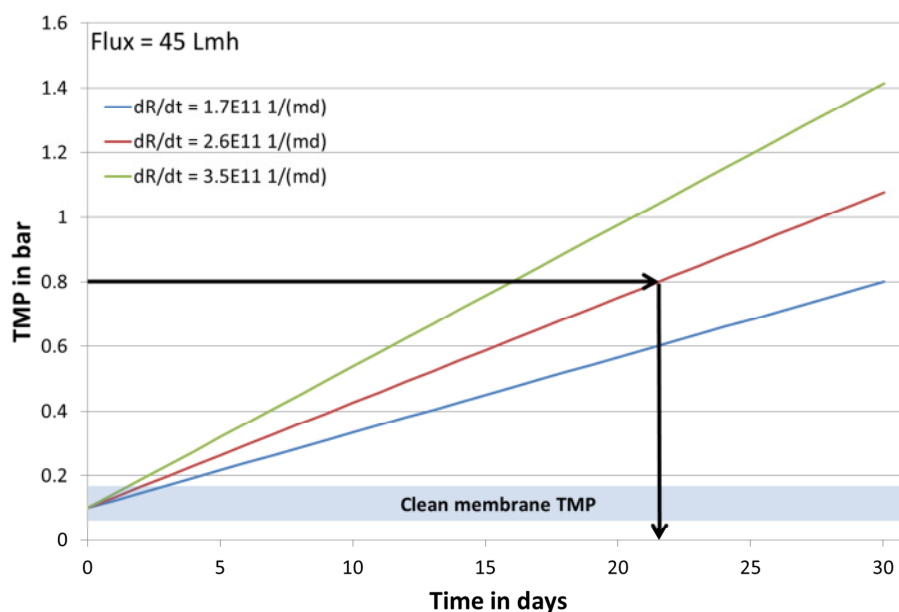

Figure 9: Theoretical TMP evolution for three different fouling rates

## 2.4.2 Permeability constraint during trial phase 1

The goal of the first phase of our trials was to screen the experimental domain using statistical trial planning, see section 2.5. Each trial run had to be evaluated independently, with no interference of the previous trials. Therefore, a permeability constraint of 300 L/(m<sup>2</sup>hbar)@20 °C was defined. Once the permeability fell below this value a CIP was carried out before the next trial run was started. Mem-X was mostly used as the caustic step since this special cleaner can assure a satisfying cleaning result. An optimization of the cleaning protocol concerning the detergents and soaking time was no goal of this trial phase. The permeability is calculated as follows:

$$L = \frac{J}{TMP}$$

where L is the permeability in L/(m<sup>2</sup>hbar); J is the Flux in L/(m<sup>2</sup>h) and TMP is the trans-membrane pressure in bar. The permeability and the flux can be corrected to 20 °C using following correction, (Trussel et al. 2005):

$$L(20\text{ }^{\circ}\text{C}) = L * \exp(-0.023 * (T - 20)),$$

respectively:

$$J(20\text{ }^{\circ}\text{C}) = J * \exp(-0.023 * (T - 20))$$

where T is the temperature in °C.

## 2.4.3 Membrane regeneration

The three ways of cleaning can be evaluated indicating the state of the membranes. This helps to realize cleaning needs in advance and to manage the operation.

Following figures are proposed and for BW and CEB these parameters can be easily implemented as online calculations.

The most direct figure during operation is the backwash effect and a dynamic comparison is proposed for evaluation. The ratio of the TMP<sub>Start</sub> of two consecutive filtration cycles should not vary outside specific boundaries.

The cleaning effect of CIPs and CEBs can be quantified by calculating the membrane **regeneration** normalized to the initial membrane permeability:

$$R_p = \frac{P_a - P_b}{P_0 - P_b} * 100\%$$

where P<sub>a</sub> is the permeability after the cleaning, P<sub>b</sub> is the permeability before the cleaning and P<sub>0</sub> is the initial permeability of the membrane.

A successful cleaning by CIP should achieve 70 - 100 % of the initial permeability. Values above 100 % indicate either a notable change of membrane characteristic or an underestimation of the initial permeability. The initial permeability of the tested module was measured with tap water before commissioning and was ~1500 L/(m<sup>2</sup>hbar)@20 °C. In order to minimize acute influences, e.g. overshoot of the feed pump, the mean values of 6 filtration cycles prior and after the cleanings were used for calculations. The cleaning effect per cycle should also be recorded. This way technical malfunction can be detected directly, for instance failure of the coagulant dosage or precipitates created during the caustic step that could not be dissolved afterwards.



**Table 6: Evaluation of cleaning methods**

<b>Cleaning method</b>	<b>Parameter</b>	<b>Target range</b>
<b>Backwash</b>	TMP <sub>Start</sub> -ratio	0.95 – 1.05
<b>Chemical Enhanced Backwash</b>	Regeneration correlated to initial permeability	-5* – 15 %
<b>Cleaning In Place</b>	Regeneration correlated to initial permeability	70 – 100 %

\*a negative regeneration by CEB can be recorded either when the membrane shows a high permeability, e.g. after CIP, or when the calculation includes too many filtration cycles after the cleaning

## 2.5 Statistical trial planning

The conducted experiments had a twofold goal: The definition of reliable operating parameters for membrane filtration and the evaluation of the beneficial effect of pre-ozonation. Because of the great number of operational parameters and their interaction, statistical trial planning was chosen to screen the way of operation. The commercial software MODDE® by Umetrics has been used to plan the trials and evaluate the outcomes.

### 2.5.1 Why statistical trial planning?

Statistical trial planning is a useful tool in R&D projects with two major advantages compared to other trial planning methods, e.g. “One variable at a time (OVAT)”:

1. The number of experiments is reduced, especially with an increasing number of parameters
2. Interaction between parameters are revealed

Due to these benefits statistical trial planning was applied in the first phase of the pilot trials. The major goal during this screening phase was to identify the experimental region of the following trial phases.

In our case the number of experiments was reduced from 81 (three levels powers four factors) to 19 including three replicate runs.

### 2.5.2 Approach – Objective screening

As mentioned above, statistical trial planning was applied in order to screen the experimental region and to define the operational parameters for the following tests. The experimental objective called **Screening** is suitable to evaluate which factors have a significant impact on the response. Screening is the first stage for describing and optimizing a process with the help of statistical trial planning and is appropriate to define a **first model**. The commercial software MODDE® has been used to plan the trials and evaluate the outcomes.

The following values were defined as **controllable factors**:

**Table 7: Controllable factors for both membrane types**

Polymeric membrane	Level	Ceramic membrane	Level
Flux	45 – 60 – 75 L/(m <sup>2</sup> h)	Flux	60 – 90 – 120 L/(m <sup>2</sup> h)
Coagulant dosage	4 – 8 – 12 mgFe/L	Coagulant dosage	4 – 8 – 12 mgFe/L
Filtration time	30 – 45 – 60 Min	Filtration time	30 – 45 – 60 Min
Backwash time	35 – 45 – 55 s	Ozone dose	0 – 7.5 – 15 mgO <sub>3</sub> /L

Flux, coagulant dosage and time of filtration are varied for both membrane types and represent the main operating tools.

The impact of the backwash time for the polymeric membranes had to be evaluated in detail, since a longer backwash time requires more filtrate, thus reducing the recovery. For the ceramic membrane the backwash regime with high pressure and a subsequent air/water flush demands very low amounts of filtrate. This low amount of filtrate used for the backwash leads to high recoveries therefore the optimizing potential is negligible. But due to the expectations combining ozonation and ceramic membranes, the ozone dose was already implemented in the first trial phase.

The water quality of the secondary effluent lies within a relatively small range, due to the optimized operation of WWTP Ruhleben. Nevertheless, the composition of the treated water may vary due to raw water constitution, throughput (e.g. daily and seasonal flow pattern) or changing biological activity. In order to be able to define the influence of the feed water quality, following compounds or parameters were defined as **uncontrollable factors**:

1. Temperature
2. Biopolymers
3. Dissolved Organic Carbon
4. Humic substances
5. Hydrophobicity
6. Turbidity
7. Total phosphorus
8. ortho-Phosphate
9. Refractory phosphorus
10. Mix Liquor Suspended Solids
11. UVA<sub>254nm</sub>

In order to reduce the number of factors some of the parameters were combined and normalized to the “water quality”. This idea was fueled by the hope to classify the filterability by a bulk parameter. This simplification could not cope with the complex nature of the water characteristics and this approach did not show the expected results.

These values were sampled and measured according to the sampling protocol and measurement guidelines, see section 2.1.

The **total fouling rate** was chosen as the **response**, because this parameter unifies all interacting values and operational options. Predicting this response enables an accurate

design of a full scale plant. This design is further on used for the global analyses via LCA and LCC.

### 2.5.3 Experimental design

With four controllable factors it is possible to design a  $2^4$ -full factorial trial campaign. The controllable factors were varied in three levels. With three center points as replicates the total number of experiments is 19 instead of 81, considering an OVAT approach.

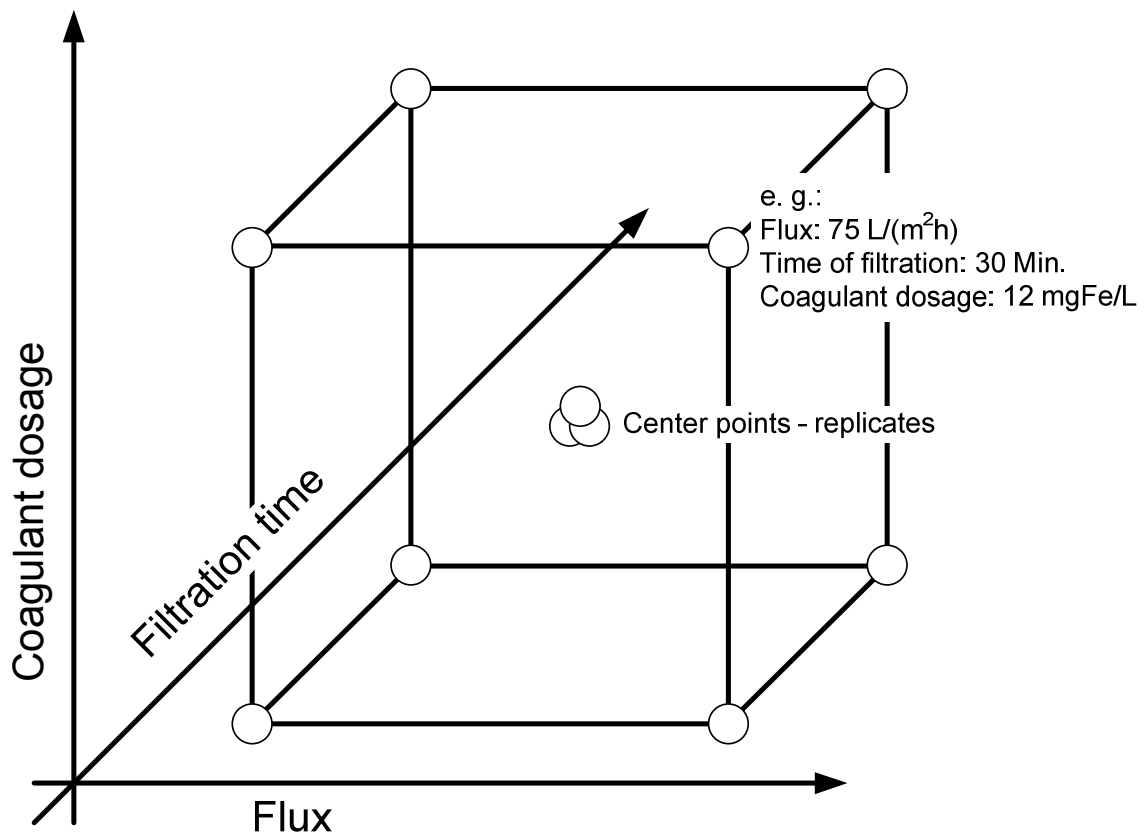

Figure 10: Experimental cube for a  $2^3$ -region

Figure 10 shows an experimental cube for three factors and the replicates. Exemplary the trial set up for one run is given. Eight additional experiments were carried out varying the fourth factor (in this example the backwash time). A hypercube-design was used to define the combination of the parameter values. The trial plan was randomized in order to reduce impacts derived from ambient nuisance, e.g. the experimenter. This means that the run order was defined coincidentally.

## Chapter 3

### Results and discussion

**The polymeric membrane** pilot provided two treatment lines which could be operated independently from each other. This was used to run two comparative studies:

1. Comparison of modules with different inner capillary diameters
2. Type of coagulant, Fe and Al (demonstration phase)

Initially the tested modules should be operated throughout the whole trial phase. Due to a fiber breakage the 40 m<sup>2</sup> module had to be replaced once and the 60 m<sup>2</sup> module was replaced twice since the early results showed an inadequate operation. The following notation is used to identify the presented data easily:

**Table 8: Notation of modules tested – polymeric membranes**

<b>UF1a</b>	Dizzer® XL 0.9 MB 60 W	Optimization & Module comparison	September 2010 – July 2011
<b>UF2a</b>	Dizzer® XL 1.5 MB 40 W	Optimization & Module comparison	September 2010 – December 2011
<b>UF1b</b>	Dizzer® XL 0.9 MB 60 W	Optimization & Module comparison	January 2012 – March 2012
<b>UF2b</b>	Dizzer® XL 1.5 MB 40 W	Demonstration & Module comparison & Type of coagulant	January 2012 – October 2012
<b>UF1c</b>	Dizzer® XL 1.5 MB 40 W	Demonstration & Type of coagulant	March 2012 – October 2012

Figure 11 shows the conducted trial phases over the two years indicating short term trials.

**The ceramic membrane** trials were carried out with two different modules. A short feasibility study of 6 weeks was conducted with a new developed membrane module manufactured by 3C (Stüber 2011). The main investigation was done with a monolithic ceramic membrane produced by Metawater.

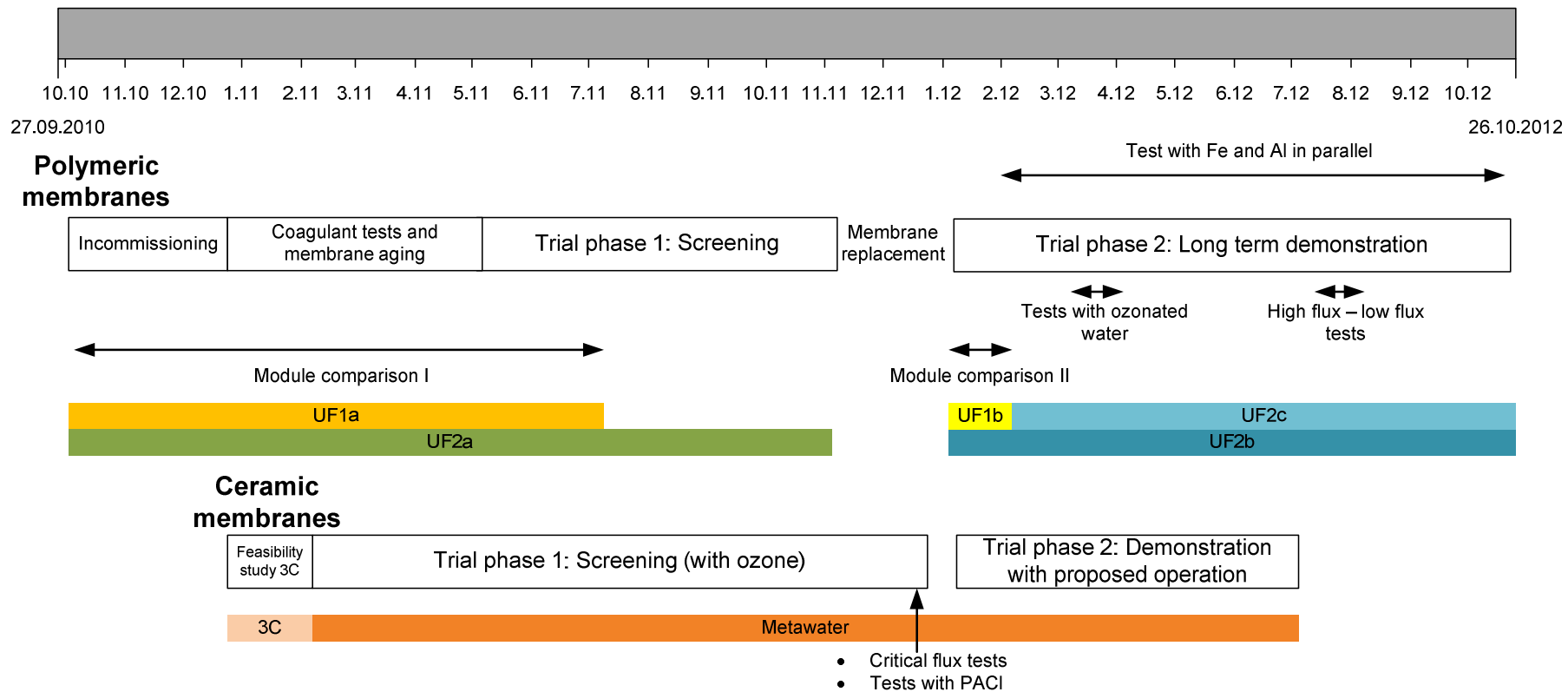

Figure 11: Trial phases

### 3.1 Water quality

The following sections describe the water analysis parameters measured in both membrane pilots throughout all experimental phases. Special interest was put on implementation of further phosphorus removal, since phosphorus is one of the major parameters addressed in the European Water Framework Directive for Berlin. The characterization of the feed water was done using all samples collected throughout the trial phases.

**Table 9: Water quality overview**

	Abb.	Unit	Feed Mean	N	Filtrate polymer	N	Filtrate ceramic	N
<b>Total Phosphorus</b>	TP	µg/L	352	214	24	96	21	73
<b>ortho-phosphate</b>	ortho-P	µg/L	92**	185	/	/	/	/
<b>Total Suspended Solids</b>	TSS	mg/L	5.4	184	< 0.1	138	< 0.1	69
<b>Chemical Oxygen Demand*</b>	COD	mg/L	38.4	163	25.6	123	25.8	23
<b>Dissolved Organic Carbon*</b>	DOC	mg/L	12.7	178	9.9	87	9.9	26
<b>Ultra Violet Absorbance (UVA) @254 nm*</b>	UVA	1/m	29.9	185	23.3	76	22.9	23
<b>Specific UVA @254 nm*</b>	SUVA	L/mgm	2.4	172	2.3	56	2.3	23

\* Values **without** ozonized water

\*\* Median lies with 62 µg/L significantly lower, see Figure 13

Most of the water parameters are shown in graphs displaying a timeline as well as a box-plot for feed and filtrate. This way a possible seasonal correlation is shown and the box-plot helps to interpret the data correctly. The box-plot shows the minimum and maximum (lower and upper end of whisker), 25 / 50 (median) / 75 percentile (box) and the mean value (square), see Figure 12.

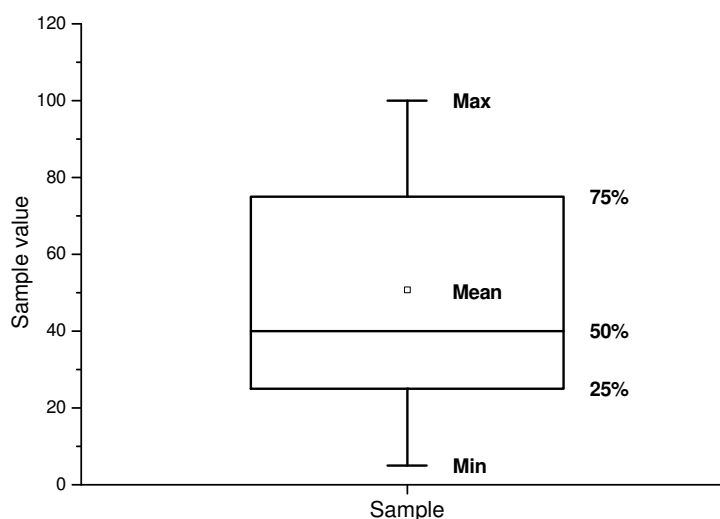
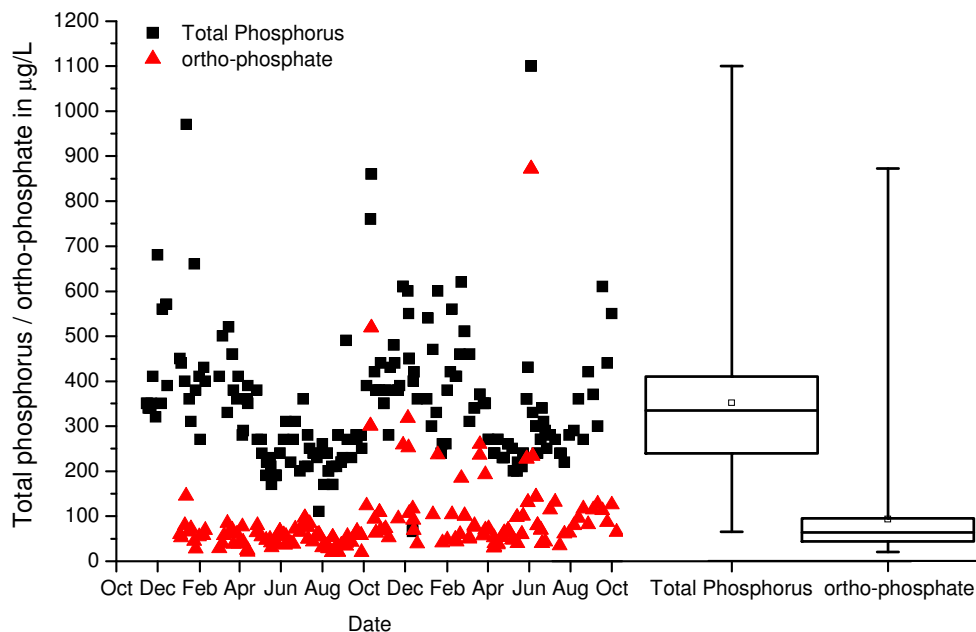

**Figure 12: Example of Whisker-Box-Plot**

### 3.1.1 Phosphorus

Since no total suspended solids pass the membrane, a reduction down to the dissolved phosphorus concentration is theoretically possible by filtration only. Further reduction is achieved by coagulation of the dissolved phosphorus, mainly ortho-phosphate as described in section 1.3.1. Figure 13 gives the timeline and a box plot for the total phosphorus and ortho-phosphate concentration in the feed. Due to the combination of biological phosphorus removal and a base dosage of  $\text{FeSO}_4$  as a coagulant applied at WWTP Ruhleben the total phosphorus concentration in the secondary effluent is with a mean value of  $352 \mu\text{g/L}$  comparatively low. The mean concentration for ortho-phosphate was  $92 \mu\text{g/L}$ .

Common  $\beta$ -factors in wastewater treatment are around  $5 \text{ mol}_{\text{Fe}}/\text{mol}_{\text{ortho-P}}$ . This means that a concentration of appr.  $1 \text{ mgFe/L}$  ( $0.0179 \text{ mol/L}$ ) would be sufficient for coagulation of ortho-P. But the purpose of coagulation in downstream membrane processes is also the flocculation of foulants. In our case the tested coagulant dosages were 4, 8, and  $12 \text{ mgFe/L}$  and the  $\beta$ -factor laid between  $25\text{-}75 \text{ mol}_{\text{Fe}}/\text{mol}_{\text{ortho-P}}$ . These values were defined during the ageing period of the membranes when coagulant dosages of  $2\text{-}4 \text{ mgFe/L}$  were tested. During this period it became obvious that the coagulant concentration assuring a stable operation with the targeted intensive operation strategy will be in a range  $6\text{-}10 \text{ mgFe/L}$ . In order to compare this rather high concentration range to results published in literature the coagulant dosage is correlated to the DOC concentration as a rough indicator of the fouling propensities. These results are further discussed in section 3.1.4.



**Figure 13: Total phosphorus and ortho-phosphate feed concentration**

Figure 14 shows the total phosphorus concentration in the filtrate for both membrane types. The mean value in the filtrate lies with  $22.8 \mu\text{g/L}$  clearly below the targeted  $50 \mu\text{g/L}$ . The ground level of  $10\text{-}20 \mu\text{g/L}$  is not removable via coagulation and porous membrane filtration. This value is specific for the WWTP Ruhleben and may vary significantly between different wastewater treatment plants. The collected data shows the robust operation in terms of phosphorus removal and the expected reliability of membrane filtration.

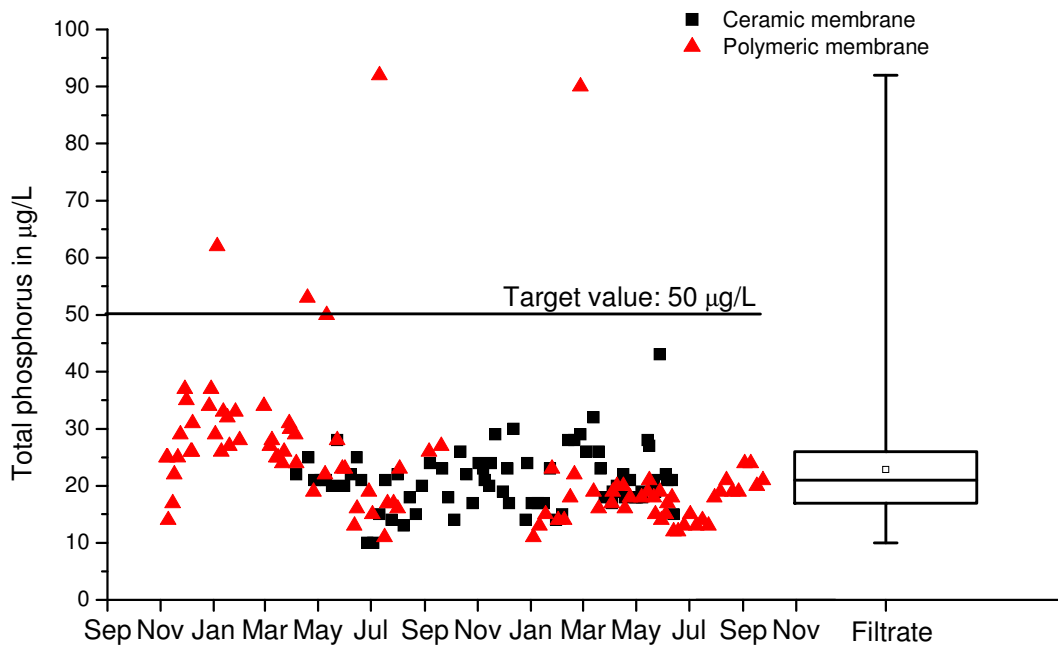

**Figure 14: Total phosphorus concentration in filtrate – ceramic and polymeric membrane**

Applying ozone as a pre-treatment step does not change the removal capacity of total phosphorus. Neither a benefit nor a drawback was recorded. In Table 10 the mean values for the ceramic membrane with no ozone and a medium or a high ozone dose is presented. The slightly lower values for coagulation alone can be explained by the lower feed concentration during this sampling period in summertime. The feed concentration was with 240 µg/L low compared to 380 µg/L during the test phases with ozone.

**Table 10: Total phosphorus concentration in the filtrate – Impact of ozonation (ceramic membrane)**

	No ozone 8 mgFe/L	N	7.2 – 9 mgO <sub>3</sub> /L 8 mgFe/L	N	15 mgO <sub>3</sub> /L 8 mgFe/L	N
<b>Filtrate TP in µg/L</b>	20	11	22	24	24	10

### 3.1.2 Total Suspended Solids (TSS)

Both membrane pilot plants were fed from the same buffer tank. The feed water quality can therefore be discussed combining the results for both pilots. Figure 15 shows a box plot of 184 samples collected between November 2010 and October 2012 with a detection limit of 0.1 mg/L. The mean value is 5.4 mg/L and the median lies slightly lower with 5 mg/L.



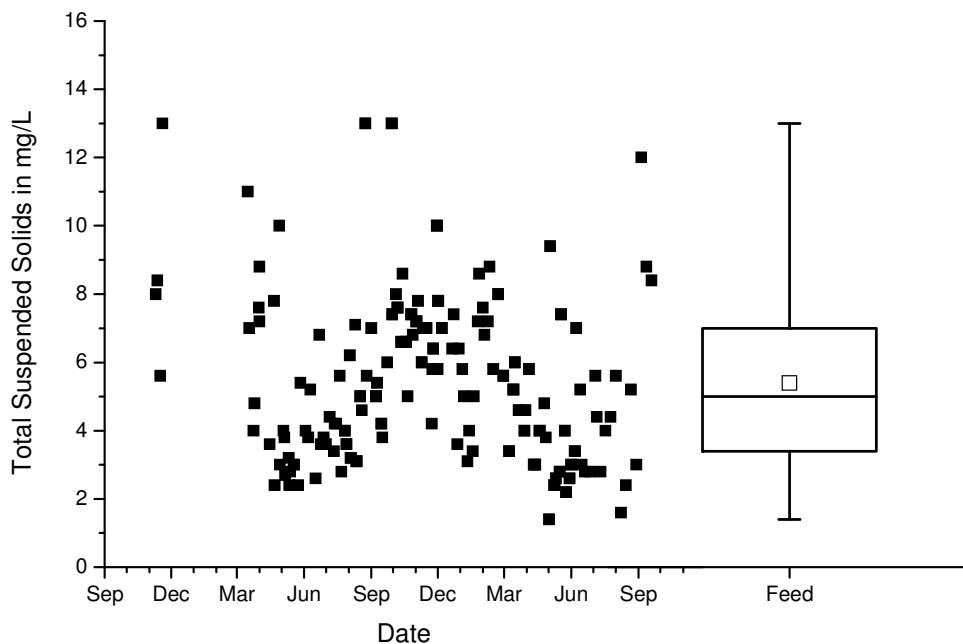

**Figure 15: Feed TSS concentration**

The evolution over time shows a seasonal correlation indicated by the lower values for summer time and higher values for the transition time and winter. Please bear in mind that most of the values were grab samples and highest values were recorded throughout the whole measurement campaign, caused by e.g. high hydraulic loads during storm weather or snow melting.

Concentrations above 0.1 mg/L of TSS in the filtrate of micro- or ultrafiltration membranes can point to the following malfunctions:

- Membrane breakage
- Post-flocculation of dissolved coagulant in the downstream piping and filtrate tank
- Biofilm formation in the downstream piping and filtrate tank used for backwash
- Precipitation during the caustic step of CEB and insufficient acidic step afterwards
- Incorrect sampling

At the end of trial phase 1 for the polymeric membranes increasing suspended solid concentrations helped to identify a fibre breakage. Figure 16 shows the evolution of the TSS for feed and filtrate of the tested Dizzer 1.5 module (UF2a). In order to rule out biofilm formation and/or post-flocculation, the piping system and the filtrate tank were cleaned with an HCl-solution (pH<2). Since the following measurements did not show any improvement further tests had to be carried out in order to verify or rule out membrane damage.

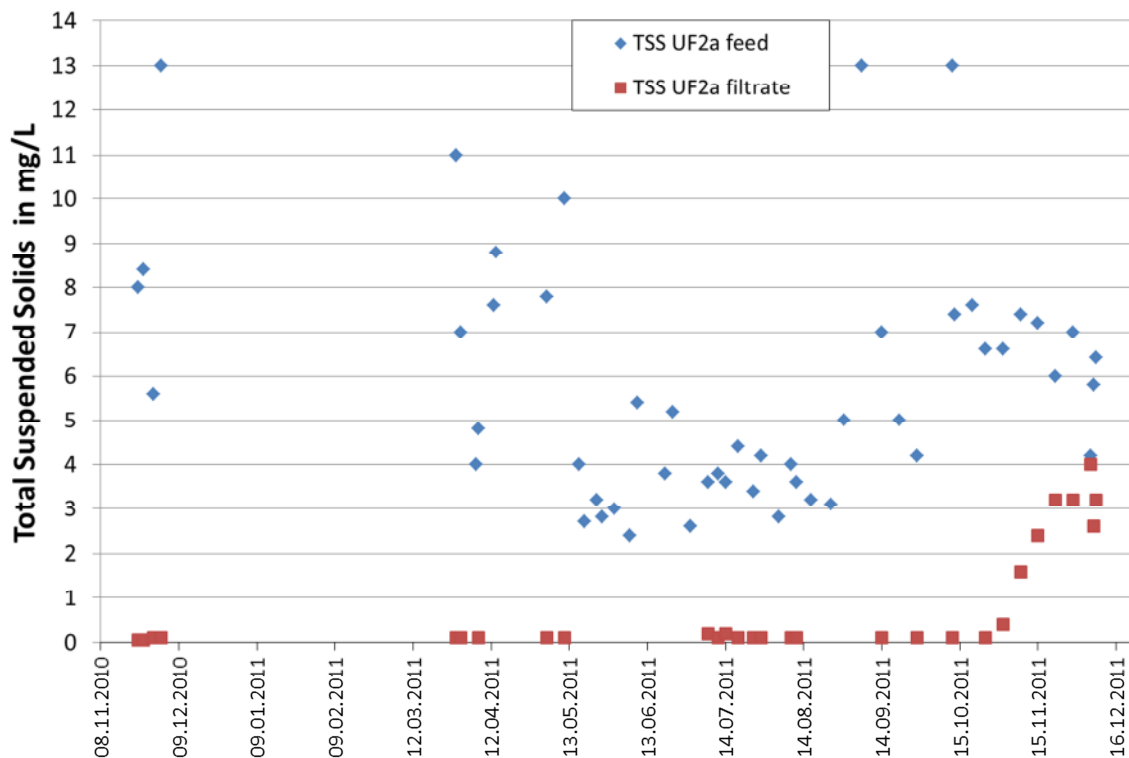

Figure 16: TSS measurements UF2a

A “pressure-hold” test conducted with the support of Inge GmbH proofed fibre damage and the module was further examined applying an autopsy and extension tests at Inge GmbH.

The results showed a decrease of mechanical strength by 23.8 % compared to a new fibre. Long term investigation by Inge GmbH with new fibres (duration 672 h at 20 °C) carried out with Mem-X (pH 12), NaOH, and HCl showed a significant decrease of the mechanical strength for the fibre soaking in MemX (-80 %). The impact of NaOH or HCl was approximately 22 % less mechanical strength. Due to the permeability constraint, see chapter 2.4.2, the operated module was cleaned comparably often with a total contact time with MemX of 426.5 h at an initial temperature of 40 °C. Inge GmbH, (Schwankhart and Krug 2012), concluded that the following reasons could have played a role in the occurred breakage:

- a single weak point (possible production error)
- pressure shock above stated limits
- contact with a large particle (inside or outside)
- The combination of one or more above mentioned points with the weakened membrane structure (caused by membrane degrading chemical agent).

The membrane module was replaced and the MLSS monitoring was further applied as a control parameter.

### 3.1.3 Chemical Oxygen Demand (COD)

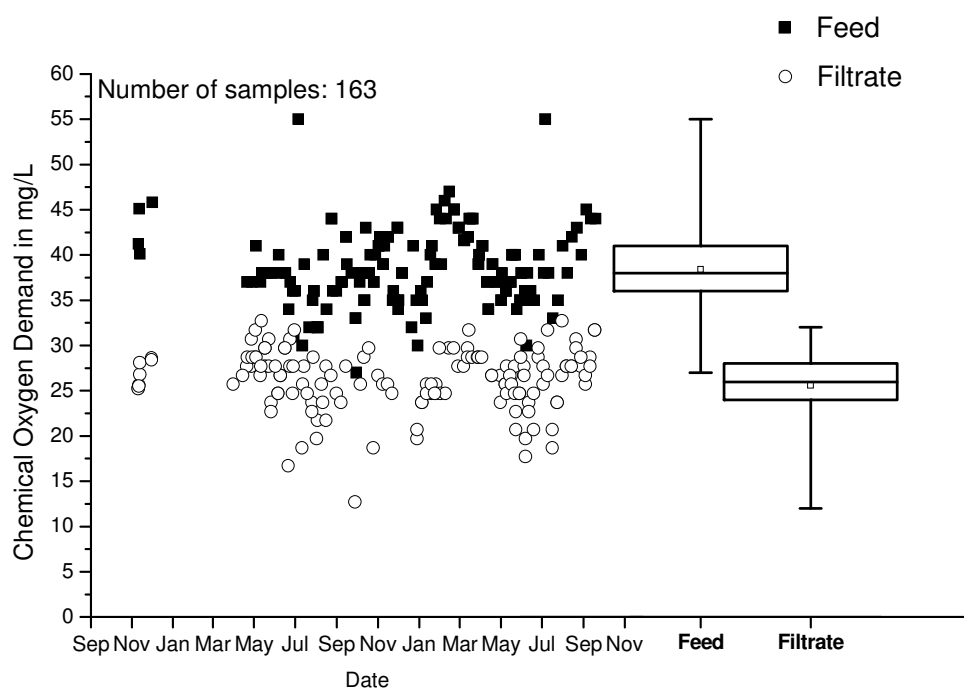

**Figure 17: Chemical Oxygen Demand – feed and filtrate**

The mean COD concentration of the secondary effluent of WWTP Ruhleben lied with 38.4 mg/L within a narrow range (StD ~ 4.4 mg/L). Considering all samples without ozonation the mean value for the filtrate was 25.6 mg/L COD, see Figure 17. The mean COD removal by coagulation and membrane filtration is therefore 33.3 %. There is no notable difference between the ultra- and microfiltration membranes (25.6 mg/L compared to 25.8 mg/L). Looking closer on the pre-treatments a differentiation between ozone and coagulant dosage is necessary.

Due to the oxidizing power of ozone the COD removal is higher when ozonation is applied and needs to be evaluated separately. This analysis was carried out only for values acquired with the ceramic membrane pilot. As described in section 2.5.3 the ceramic membrane was operated with medium (7.5 mgO<sub>3</sub>/L) and high (15.0 mgO<sub>3</sub>/L) ozone doses. Since the coagulant dosage was also varied the removal performance can only be evaluated with respect to both pre-treatments. Figure 18 shows the removal with respect to the pre-treatment. The highest removal was detected when applying 15 mgO<sub>3</sub>/L and 12 mgFe/L. In relation to the dissolved organic carbon (DOC) a mean specific ozone dose of 1.17 mgO<sub>3</sub>/mgDOC was applied for these measurements.

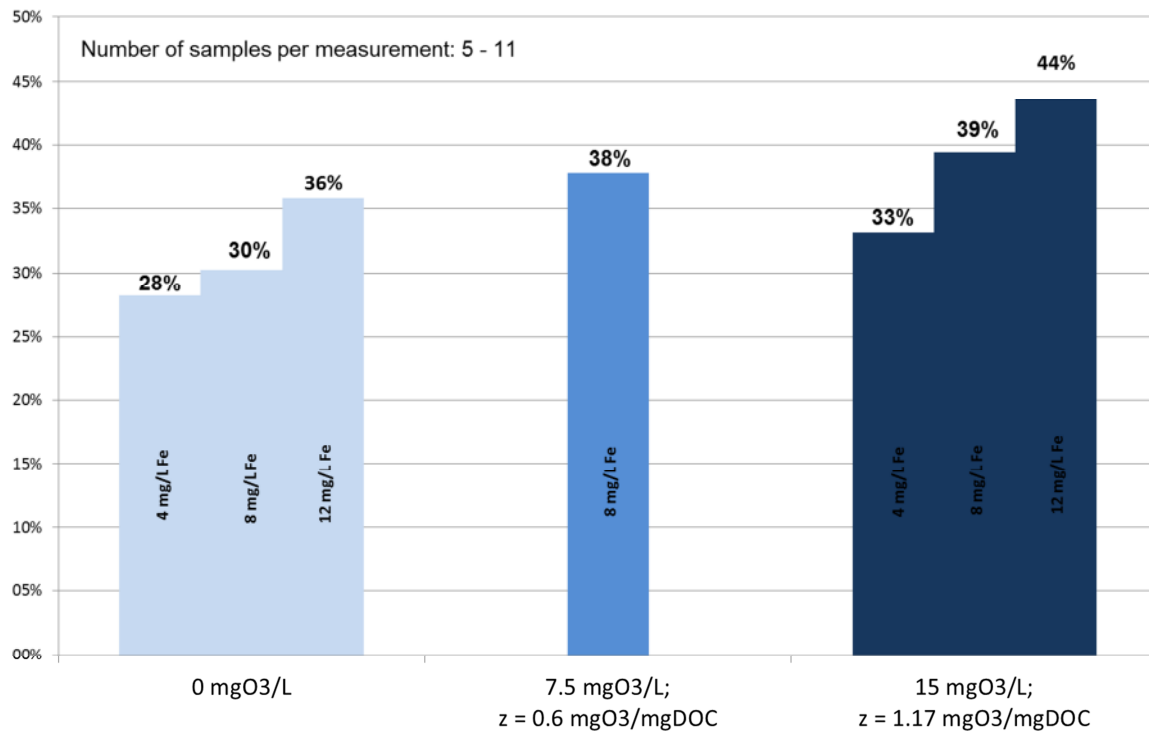

**Figure 18: COD removal correlated to the ozone and coagulant dosage (ceramic membrane)**

### 3.1.4 Dissolved Organic Carbon (DOC)

Figure 19 shows the feed DOC concentration throughout the two years of experimentation of all membranes. In opposite to surface water no seasonal correlation is clearly shown. The feed mean value was 12.7 mg/L as well as the median. 178 samples were evaluated during the trials. The box plot indicates that the 75 % of the samples lied below 14 mg/L and 50 % of all samples were between 12 and 14 mg/L. This rather high DOC concentration can be explained by the nature of the upstream soil. Terrestrial peat causes a high concentration of humic DOC throughout the regional water cycle. A differentiation of the DOC removal performances between the applied coagulant dosages and ozone doses is given in Figure 20 and Figure 21. A closer look on the impact of each individual pre-treatment step on the foulants is given in section 3.1.6 focusing on the biopolymers. DOC removal by ozonation alone is reported in literature to be approximately 10 % when applying high specific ozone doses ( $z > 0.9$  mgO<sub>3</sub>/mgDOC) (Van Geluwe et al. 2011). This removal capacity was not confirmed during our trials at WWTP Ruhleben. Solely the coagulant concentration was shown to have an impact on DOC removal.

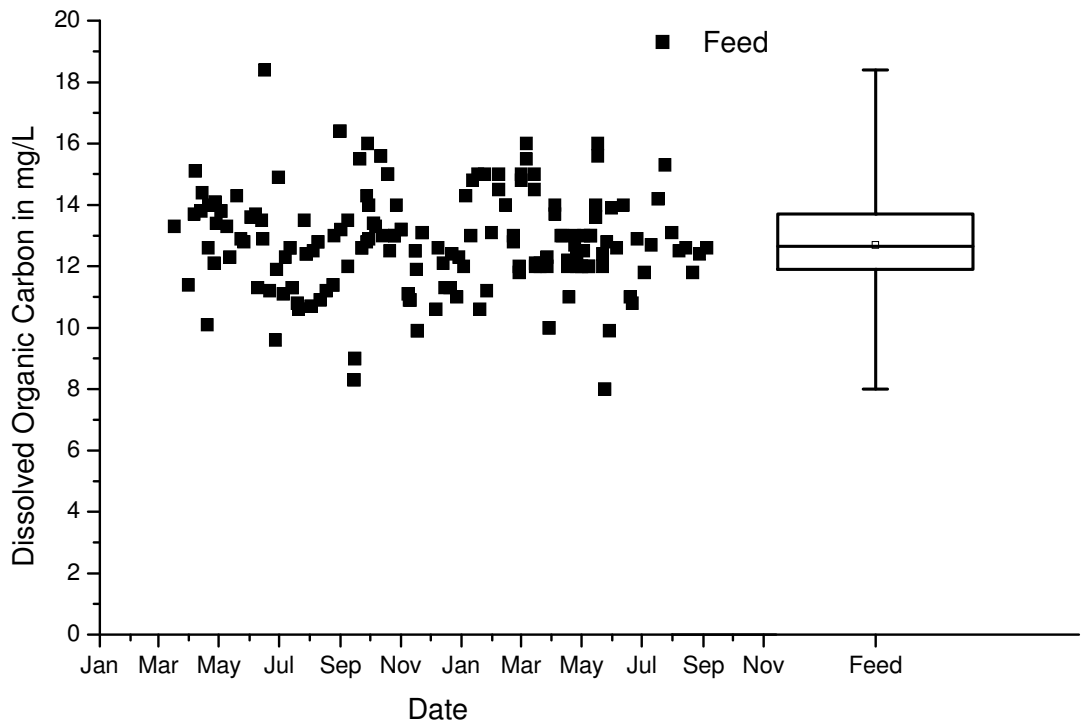

Figure 19: DOC concentration – Feed

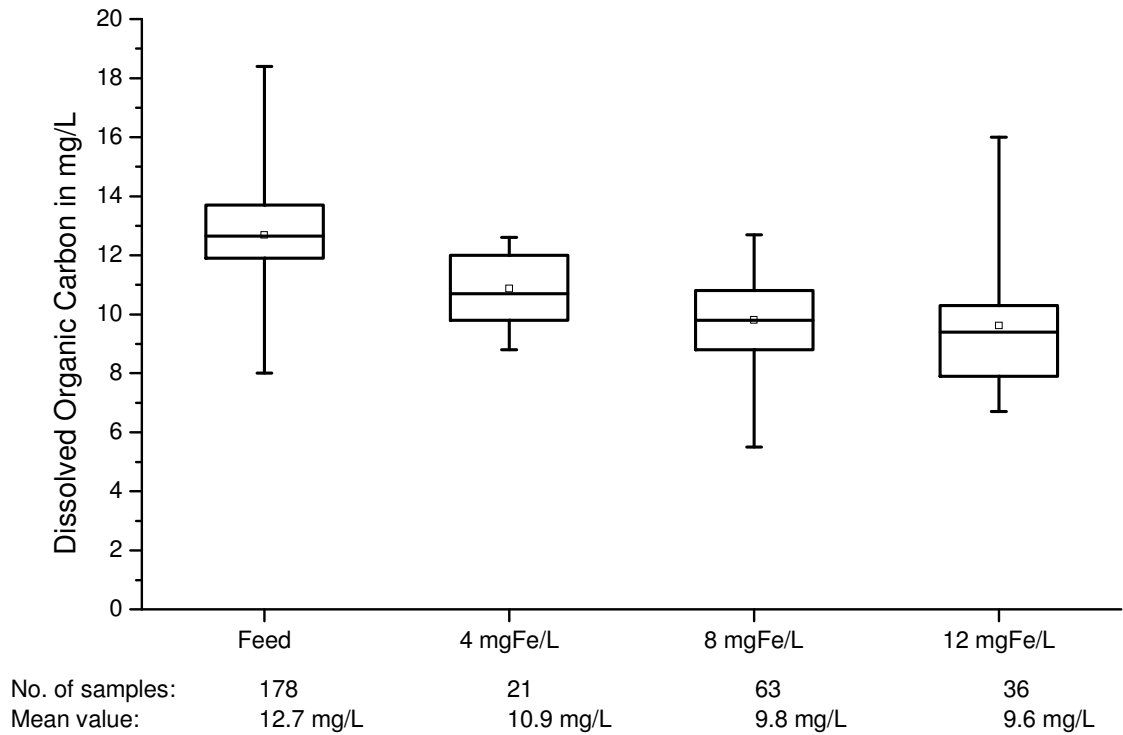

Figure 20: DOC - Feed & filtrate - Impact of coagulant concentration (without O<sub>3</sub>)

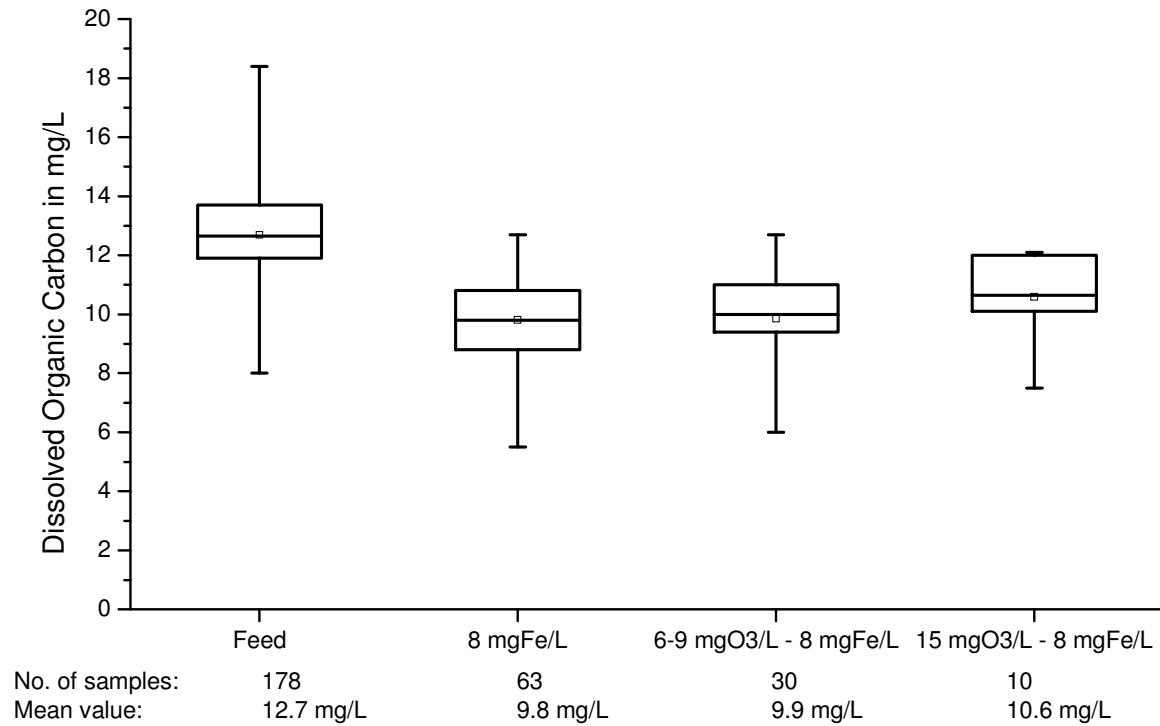

Figure 21: DOC - Feed & filtrate - Impact of ozone dose

### 3.1.5 UV absorbance @254 nm

UV absorbance helps to identify the nature of organic matter (OM) in terms of the aromatic character. The feed mean value was 29.9 1/m see Figure 22.

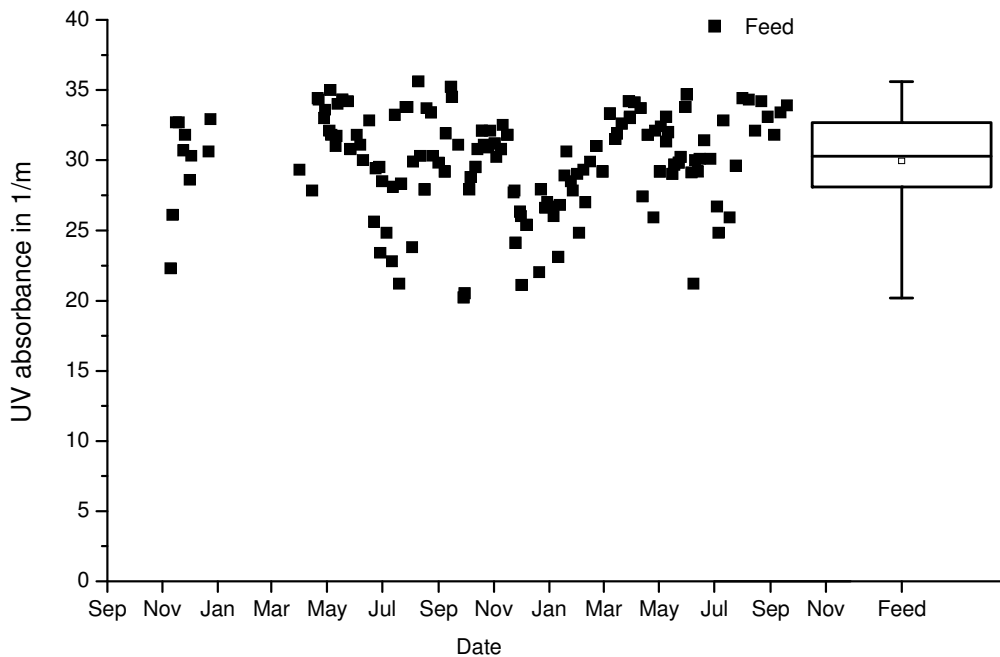
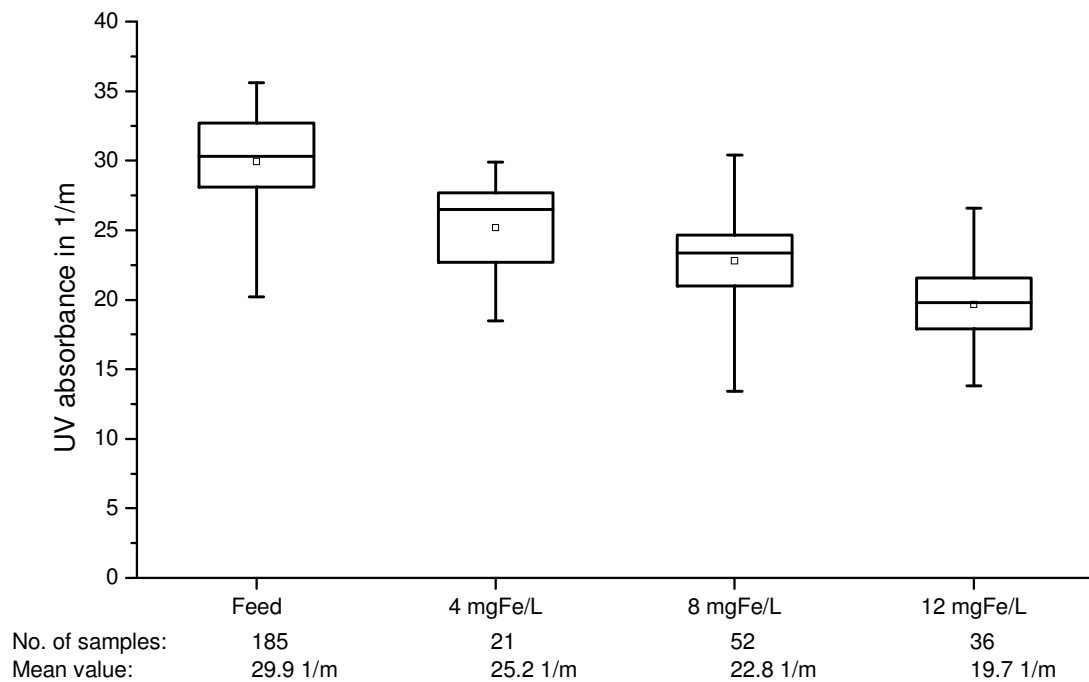
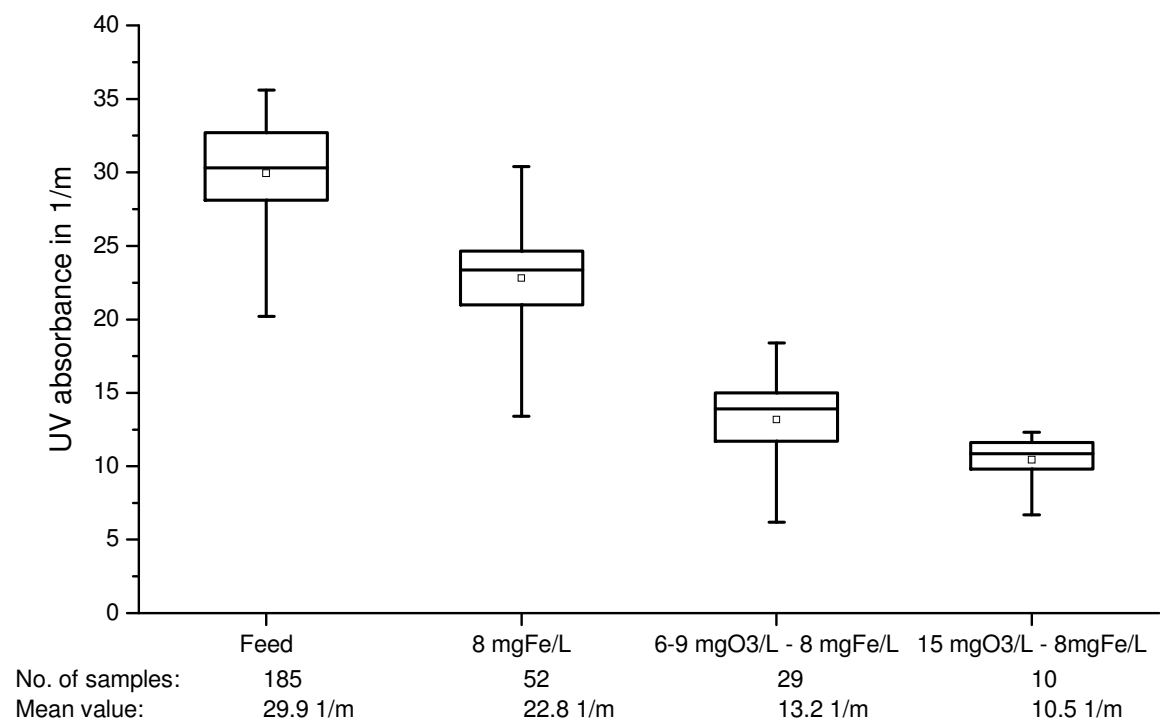

Figure 22: UV absorbance – Feed

A differentiation between the pre-treatments, coagulant and ozone dosage, is necessary evaluating the results for the filtrate, see Figure 23 and Figure 24.



**Figure 23: UV absorbance - Feed & filtrate - Impact of coagulant concentration**

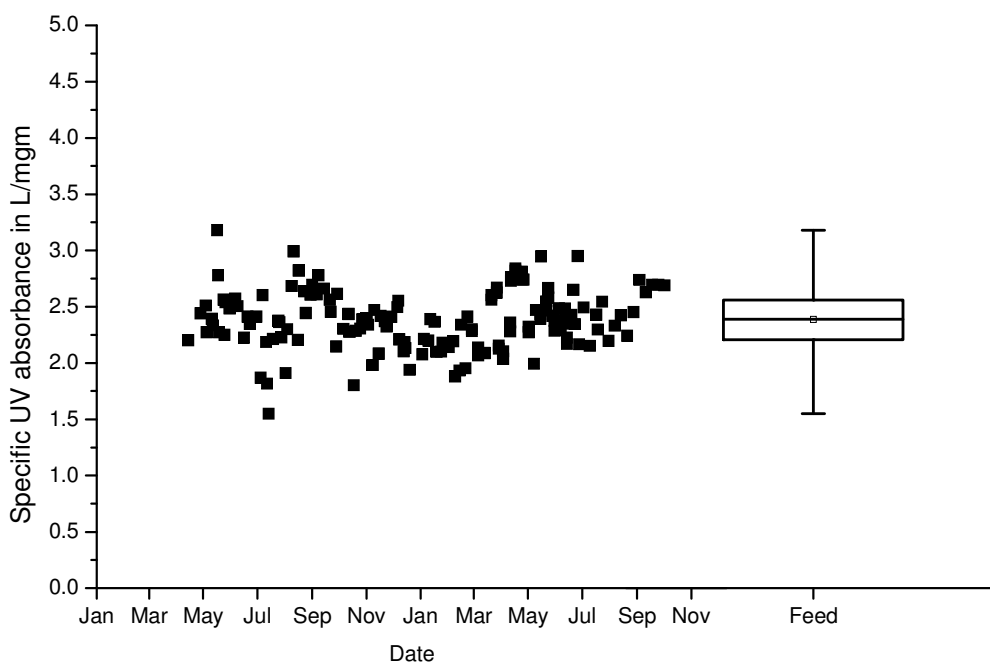

**Figure 24: UV absorbance – Feed & filtrate – Impact of ozone dose**

As expected further UV reduction was observed when ozone was applied. Figure 24 shows the results with 8 mgFe/L and according to the ozone dose. The medium ozone dose lies between 6 and 9 mg/L ( $z = 0.47 - 0.7 \text{ mgO}_3/\text{mgDOC}$ ) and the high dose corresponds to 15 mg/L ( $z = 1.18 \text{ mgO}_3/\text{mgDOC}$ ). This shows that coagulation is non-selective between aromatic compounds of the organic fraction, see Figure 26: The aromatic fraction is removed similarly by coagulation than the whole organic fraction. If ozonation does not impact on the quantity of organic carbon (see DOC results Figure 21), it appears that ozonation impacts on the constitution of the organic substances as seen with the reduction of UVA in Figure 24 (oxidation and breaking down of aromatic rings) together with decolorization.

### **Specific UV absorbance**

The correlation of the UV absorbance to the DOC is used to estimate the relative amounts of humic substances attributing to the OM. Higher values indicate a large fraction of humic substances and lower values show a non-humic character of the OM (Amy 2009). The mean feed SUVA was approximately 2.4 L/mgm. There is no distinctive reduction due to coagulation and filtration alone, as both values (UVA and DOC) are lowered by the pre-treatment and the subsequent filtration.



**Figure 25: Specific UV absorbance in the feed**



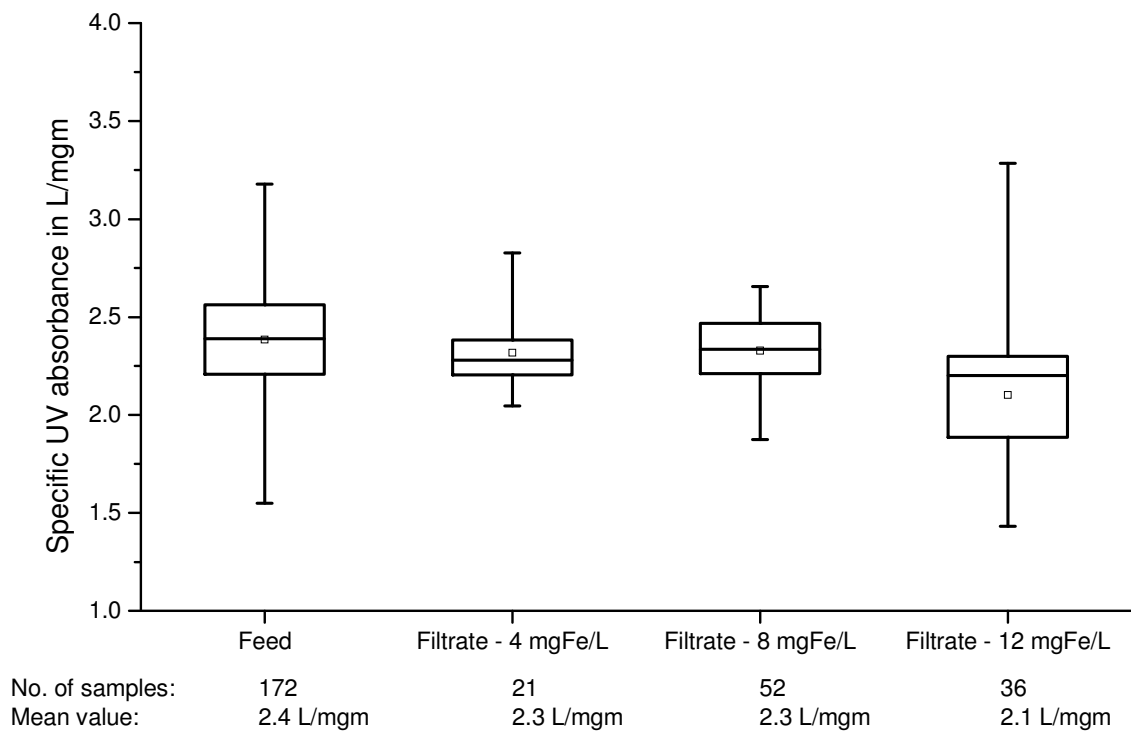

**Figure 26: Specific UV absorbance – Feed & filtrate – impact of coagulant concentration**

In contrary ozonation changes the photo-chemical characteristics of the present compounds, see Figure 27. UV absorbance is lowered significantly while the DOC is reduced moderately or not at all. Therefore the SUVA is reduced further when ozone is applied. This is due to the oxidation and breaking down of the aromatic compounds. Similarly, the transformation of biopolymers to smaller compounds can be seen through LC-OCD results presented in the following section.

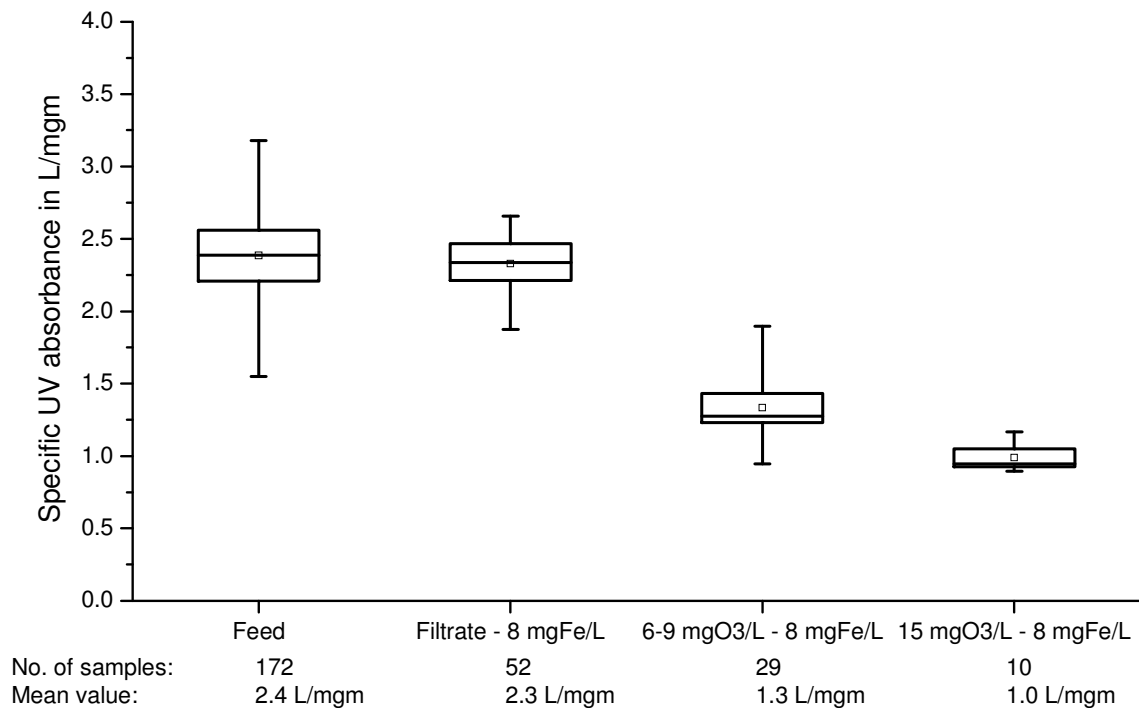

**Figure 27: Specific UV absorbance – Feed & filtrate – impact of ozone dose**

### 3.1.6 LC-OCD

The biopolymer fraction of the DOC plays a major role for fouling control and the applied pre-treatments focus on the reduction or transformation of these foulants. The following chapter addresses the fractionation of DOC through LC-OCD measurements.

All LC-OCD analysis with quantitative data evaluation was carried out by Manuel Godehardt and his colleagues at TU Berlin, Chair of Water Quality Control. The following interpretation was compiled during many discussions and meetings within the OXERAM project. Correlating the laboratory analysis to the pilot plant operational behaviour is presented in section 3.2. Further detailed investigations with a bench scale filtration unit addressing the fundamental mechanisms of membrane fouling in relation to the pre-treatment can be found in D4.2 by Godehardt et al. 2013. Also a more detailed description of the applied analytical methods is presented there.

Liquid chromatography with organic carbon detection was used for DOC fractionation and the effects of biopolymer reduction through ozonation and coagulation as well as coagulation alone were investigated. Chromatography helps to differentiate between the different organic carbon fractions present in secondary effluent. Figure 28 shows an exemplary chromatogram for WWTP Ruhleben secondary effluent, which is the influent of the membrane pilots. The different fractions are determined through the retention time and the concentration can be calculated through the enclosed area within a specific retention time (Huber et al. 2011).

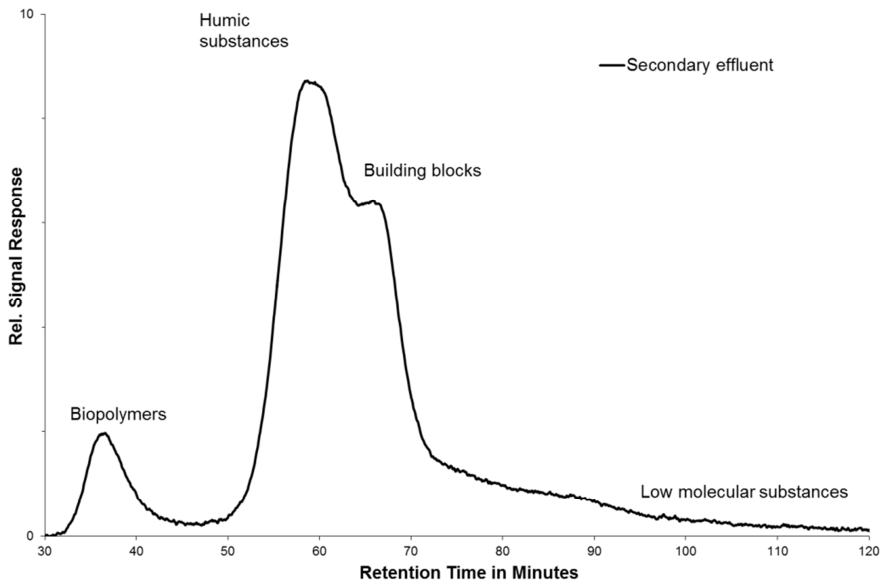

**Figure 28: LC-OCD chromatogram - WWTP Ruhleben secondary effluent**

Biopolymers (BP), consisting of proteins-like and polysaccharide-like compounds, were identified to play a major role in membrane fouling by many research groups. The goal for pre-treatment schemes prior membrane filtration is therefore the reduction of free BP reaching the membrane surface. Figure 29 shows the BP concentration in the feed as a timeline and a box plot. During the project the analysis column was replaced by a column with a wider pore size diameter, indicated by the straight line in the graph. Besides the last samples with the old column and the first and last samples with the new column, the concentration varies within the previously measured range. The mean value is 0.64 mgC/L and the median is slightly lower. The timeline indicates that the BP concentration in the secondary effluent of Ruhleben does not follow a seasonal trend and differences in the range of 0.4 mgC/L within a day can appear. Zietzschmann 2011 confirms the neglectable seasonal impact for the secondary effluent of WWTP Ruhleben throughout his long term measurement campaign.

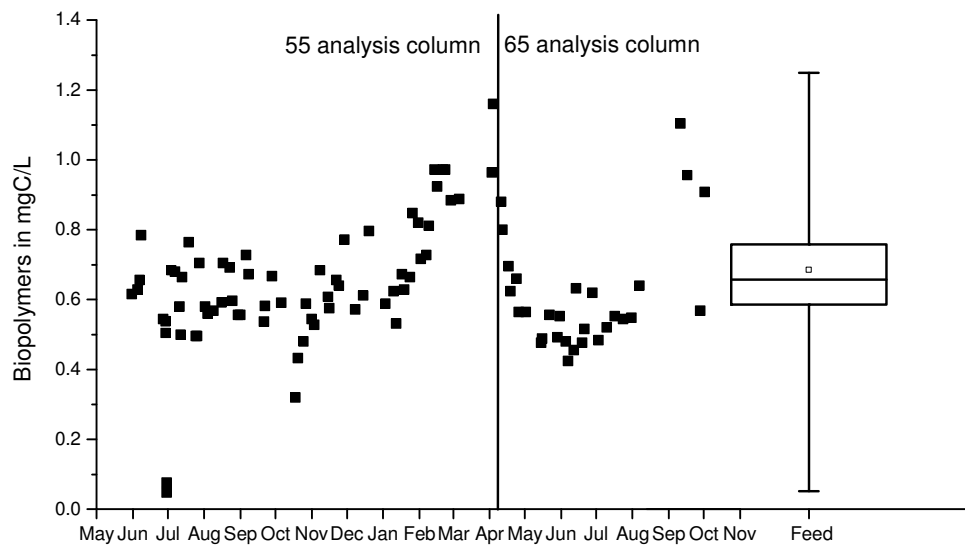

**Figure 29: Biopolymer concentration in the feed**

Biopolymers contribute only with about 5-6 % to the DOC concentration in the influent, but they have high propensity to attach to the membrane surface and can cause severe membrane fouling.

Highlighting the “biopolymer peak” of Figure 28 the effect of the different pre-treatments is shown in Figure 30.

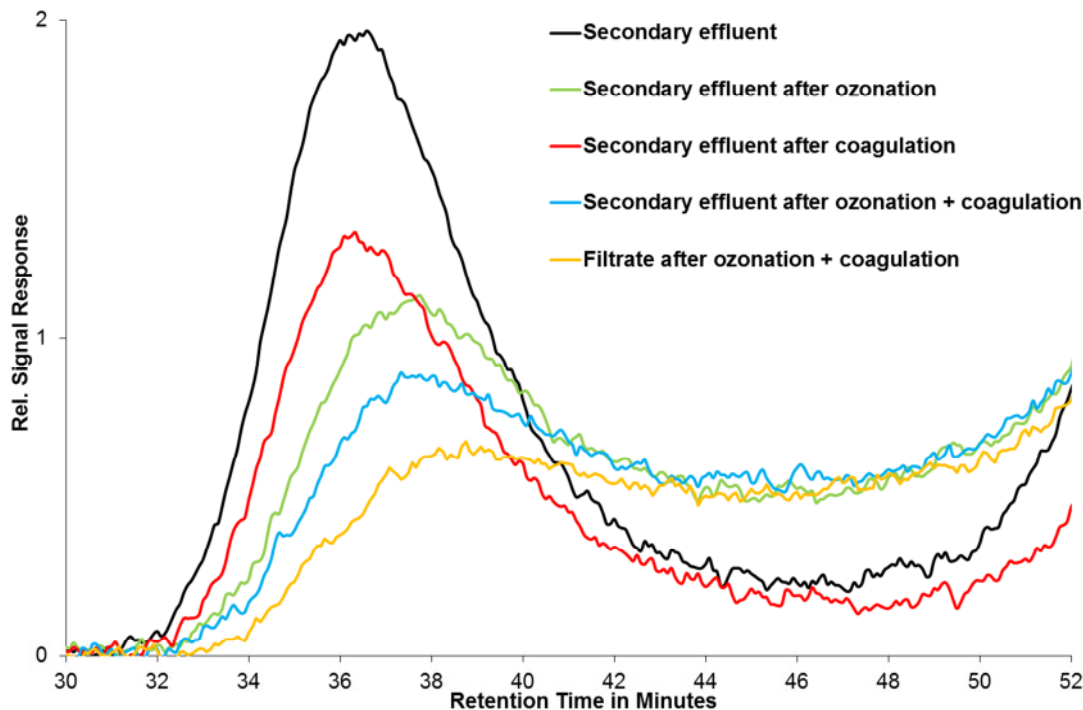

**Figure 30: Biopolymer peak in relation to treatment (ceramic membrane filtrate)**

The following pre-treatments were applied:

- 15 mg/L of ozone ( $z = 1.3 \text{ mgO}_3/\text{mgDOC}$ )
- 8 mg/L of ferric

The reduction of biopolymers due to coagulation alone was evaluated using a sample of the polymeric membrane pilot plant operated in parallel and applying the same amount of coagulant. Coagulation or ozonation alone reduces the biopolymer concentration and combining both treatments decreases the biopolymer concentration a little further. Two different mechanisms are responsible for the reduction of free biopolymers:

- Ozonation transforms biopolymers into smaller compounds that can pass the membrane pores.
- Coagulation binds colloids and small particles to form larger compounds that are removed by filtration. The amount of free biopolymers reaching the membrane surface causing fouling is therefore reduced.

The latter effect is clearly shown by the chromatograms of ozonized water (green and blue curve) at a retention time of 42 – 52 minutes. The graphs show an increased value for ozonized water and comparing the signal with the filtrate (yellow curve) shows that these newly formed compounds did not attach to the membrane surface but passed the membrane. The amount of biopolymers retained by the membrane surface and the cake layer can be estimated considering the area between the sample curves.

The mean reduction achieved with different pre-treatments (medium ozone (7.2 - 9 mgO<sub>3</sub>/L) and coagulant (8 mgFe/L) dosage) is shown in Figure 31.

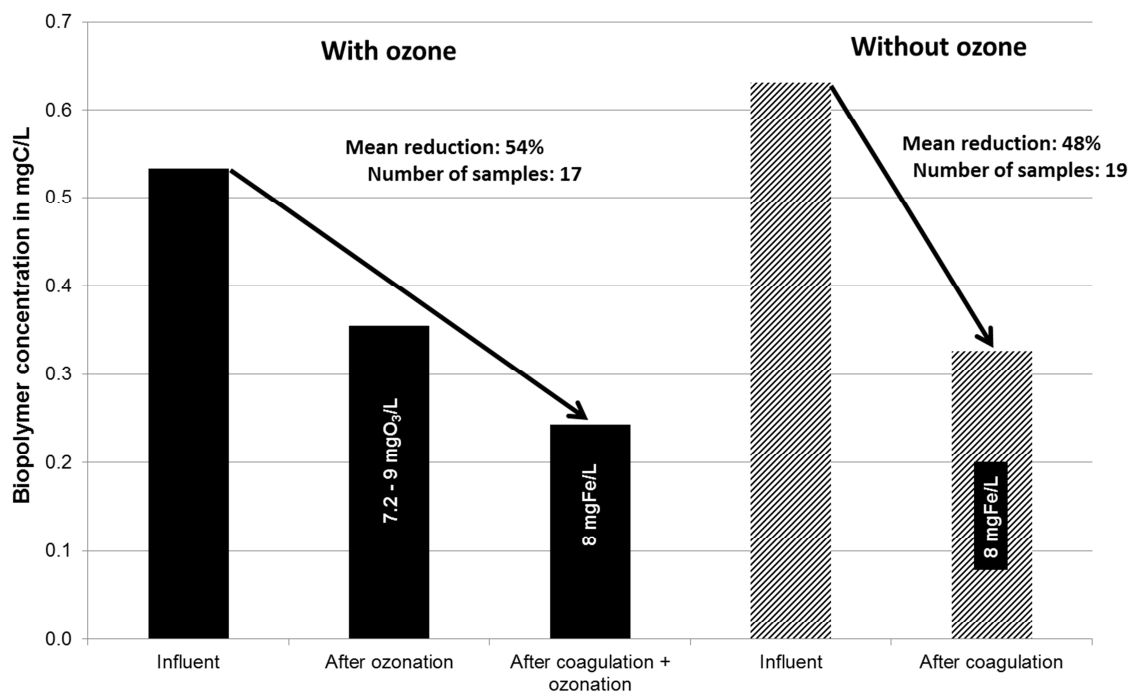
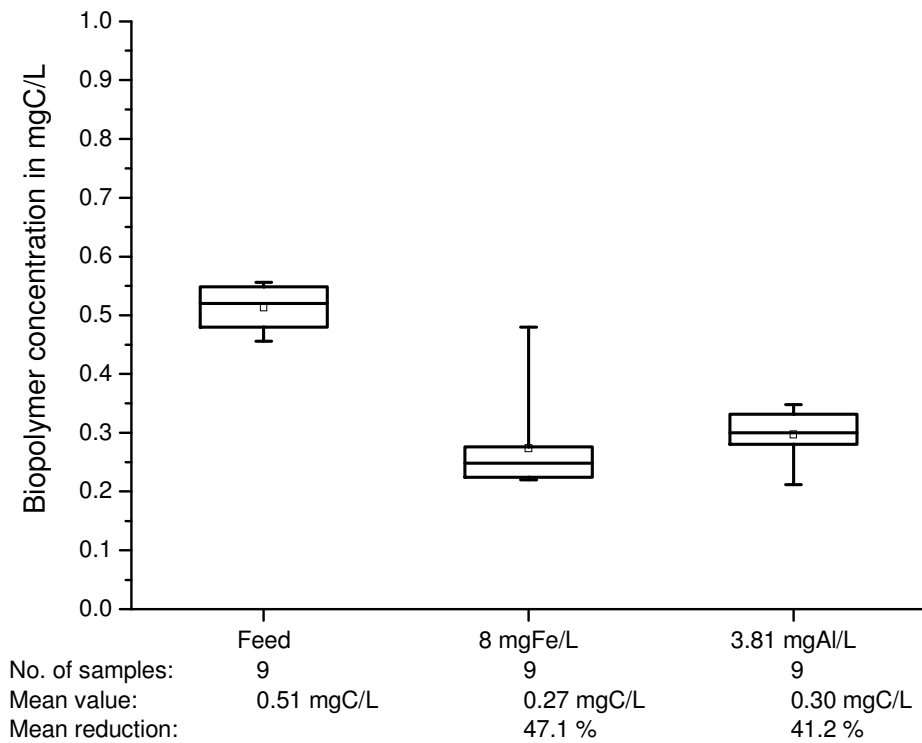

**Figure 31: Biopolymer reduction by pre-treatment**

The biopolymer reduction with the combination of ozonation and coagulation is slightly higher than coagulation alone (54 % vs. 48 %), but the effect of ozonation on the filtration performance cannot be explained by this reduction. The major effect of ozonation reducing the fouling potential can be attributed to the **transformation** of biopolymers. A clear separation between the positive, enhancing effects during pilot plant operation is difficult, because it is not possible to link the fouling rate reduction to one effect alone.

**Coagulant comparison – impact on biopolymer reduction**

During the long term validation for the polymeric membranes both filtration lines were operated in parallel using Al and Fe as coagulants. During these trials a concentration of 3.81 mg/L Al and 8 mg/L Fe were applied (0.143 mmolMe/L). The ozone dose was in a medium range (6 - 7.2 mg/L) for the presented data. The results for biopolymer reduction according to pre-treatment during this parallel operation are shown in Figure 32 and Figure 33. Only sample pairs (*feed, after coagulation* or *after ozonation + coagulation*) are presented. Therefore the mean values for the feed varies between each other. The mean biopolymer reduction by coagulation and ozonation + coagulation was between 41.2 % and 56.5 %. A slightly higher reduction was achieved when ozonation was introduced before coagulation, as described in the previous paragraph. The difference in reduction between the two coagulants, with or without ozone, is less than 10 % and no clear advantage of one over the other can be distinguished. This could be confirmed by the filtration performances of the 2 polymeric units operated with each coagulant type, see section 3.2.5.



**Figure 32: Biopolymer reduction – coagulant comparison**

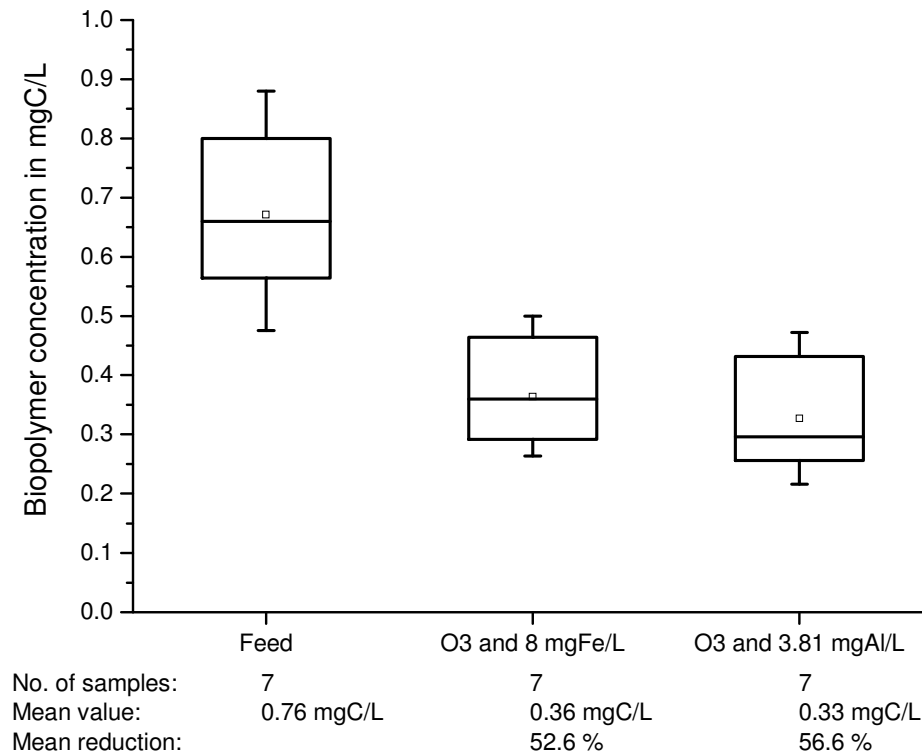

**Figure 33: Biopolymer reduction – coagulant comparison with ozonation (6 – 7.2 mgO<sub>3</sub>/L)**

### 3.1.7 Eco-toxicity

Using ozone as a pre-treatment step raises the question about by-products and their effects on the ecology of the receiving water body. A brief screening with two measurement campaigns was carried out within OXERAM. Each measurement campaign included samples for influent, ozonized water (before coagulation), and filtrate. The ozone dose for the first campaign was 15 mg/L and 7.5 mg/L for the second campaign. The following standard eco-toxicity tests were performed:

- Enzyme activity (Glutathione S-transferase (GST) and peroxidase (POD))
- Ames test according to OECD471
- UMU-Chromo test according ISO 13829
- AChE inhibition assay
- Luminous bacteria test

The tests were carried out by TU Berlin, Institute of Ecology, Department Ecological Impact Research and Ecotoxicology.

One influent and one filtrate sample showed a noticeable effect on the enzyme activity tests GST and POD, but there was no correlation to ozonation. The complementary tests did not show any significant effect.

A complete evaluation of eco-toxicity of by-products by ozonation cannot be given with this low number of samples. Current research projects carried out in Berlin address the issue of eco-toxicity on a broader range with an adequate sampling campaign.

Ozonation has an impact on some of the prior discussed water quality parameters, but the major reason combining ozonation and membrane filtration is the possible reduced fouling propensity leading to lower investment and operational costs. The following chapter describes the effects of ozonation on the two membrane materials tested.

#### **Summary**

- TP concentration in the filtrate  $\ll 50 \mu\text{g/L}$  (Mean  $24 \mu\text{g/L}$ )
- COD removal by membrane filtration  $\sim 33 \%$
- Ozonation transforms biopolymers into smaller compounds/colloids
- Biopolymer reduction by coagulation (Fe and Al show similar results)
- Pre-ozonation does not increase biopolymer reduction significantly

### 3.2 Polymeric membrane operation

The polymeric membrane trials were carried to answer several questions arising when an upgrade of full scale treatment plants with a membrane filtration step is being discussed. The parallel operation of two membrane modules offering a different membrane surface ( $40$  and  $60 \text{ m}^2$ ) was used to compare the different operational behaviour of both modules. Verification of the feasibility for the  $60 \text{ m}^2$  module could lower the investment costs significantly, thus reducing one of the major draw-backs of membrane filtration. This comparison was incorporated in the trial phase 1 when statistical trial planning was used and later on repeated for validation, see section 3.2.1 and 3.2.2.

Once a reliable way of operation was defined the influence of pre-ozonation could be tested. Only few results for lab scale investigations were published so far and a safe operation combining pre-ozonation and polymeric membranes in pilot scale had to be proven. Within the Oxeram project three protection mechanisms were implemented against the risk of ozone residual reaching the polymeric membrane and tested, see section 3.2.6.

The cleaning strategy has a strong impact on the economic evaluation therefore the results were used to identify the requirements for a robust operation, see section 3.2.3.

The proposed operating strategy was verified and used for the coagulant comparison with Al and Fe used in parallel, see section 3.2.5

In order to adapt a membrane filtration stage to the needs of a full scale plant with a daily flow pattern and minimizing the installed membrane surface, an operation scheme with two fluxes was tested for two weeks, see section 3.2.6.

### **3.2.1 Module comparison**

Operating the Dizzer® XL 0.9 module in wastewater treatment processes bears an enormous saving potential, because the costs per m<sup>2</sup> membrane surface is ~ 30 % lower compared to the Dizzer® XL 1.5 module. Two approaches comparing the different capillary diameters were chosen:

1. Equal flow

Both modules were operated with the same flow (i.e. +50 % flux in Dizzer 1.5 than Dizzer 0.9), thus the investment for the membrane modules and the periphery is similar. Lower fouling rates for either one of the modules would result in lower cleaning needs and thus in lower operating costs.

2. Equal flux

Operating the membrane modules with the same flux bears the potential to reduce the investment and re-investment costs by 33 %, providing that the 0.9 mm modules can be operated reliably.

During trial phase 1 the equal flow approach was used and evaluated using the fouling rates, thus the cleaning needs. Due to trial randomization both treatment lines were not operated with the same set-up and the permeability constraint resulted in an increased cleaning demand for the 0.9 mm module. In the early stage of trial phase one, the backwash for the 0.9 mm module was insufficient, due to an insufficient backwash flux. This led to a vicious circle: high fouling resulted in a high head loss during backwash, in consequence lower backwash fluxes were achieved once the backwash pump was running at the limit, and thus the cake layer and foulants were not washed out properly. After the next filtration cycle the head loss increased furthermore and the backwash became more and more inefficient. The backwash pump was adapted to the needs of the 0.9 mm module and for the following trials of trial phase 1 and the 2<sup>nd</sup> module comparison campaign a sufficient backwash flux was assured.

The 2<sup>nd</sup> module comparison campaign was carried out with an equal flux and the same operational set-up in the beginning of trial phase 2. This allows a direct comparison of the filtration performance. Figure 34 shows the fouling resistance for the first 60 days of operation.



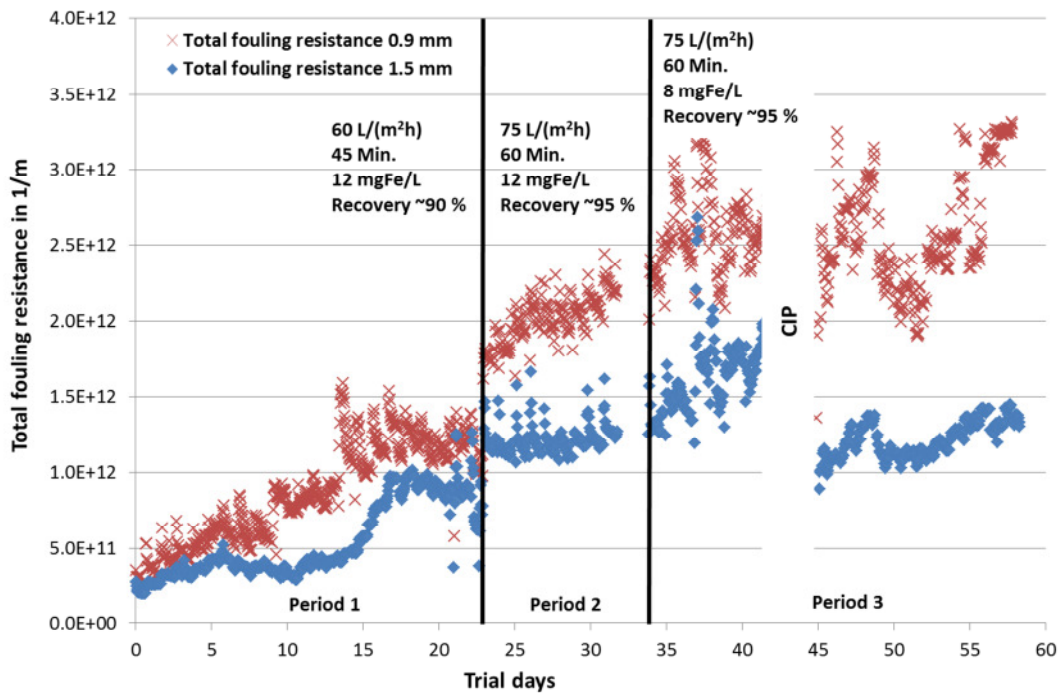

**Figure 34: Total fouling resistance 2<sup>nd</sup> module comparison campaign**

Commissioning the new modules was done with a medium operation strategy, a flux of 60 L/(m<sup>2</sup>h), 45 min. and 12 mgFe/L. Since the total fouling resistance was in an acceptable range after 23 days, the flux was increased to 75 L/(m<sup>2</sup>h) and 60 min. achieving the targeted recovery of 95 %. With this intensive operation a notable drift of the total fouling resistance between the two modules was recognized. Later on the coagulant dosage was reduced to 8 mgFe/L and a CIP was carried out when the trans-membrane pressure exceeded 0.8 bar. In Table 11 the correspondent total fouling rates are given.

**Table 11: Module comparison - Total fouling rates**

	0.9 mm module (UF1b)	1.5 mm module (UF2b)
<b>Total fouling rate period 1</b>	0.39E+11	0.3E+11
<b>Total fouling rate period 2</b>	2.22E+11	0.86E+11
<b>Total fouling rate period 3</b>	2.17E+11	1.87E+11
<b>Regeneration by CIP</b>	36 %	69 %

When operating with 95 % recovery/high flux, two major drawbacks of the 0.9 mm module as shown in Figure 34 are:

1. The fouling rate is higher, thus shorter CIP intervals are necessary.
2. The CIP was not able to regenerate the membrane sufficiently, thus the resistance remains on a comparably high value.

Clogging of some of the capillaries is neither flushed off by backwash nor by CIP leading to a loss of membrane surface. This causes a higher surface load of the remaining open capillaries and subsequently to a high initial resistance and higher fouling rates.

The results of both module comparison campaigns led to the conclusion that the 0.9 mm capillary module shows an unsteady operation with an intensive operation strategy, e.g.

with fluxes  $\sim 75 \text{ L}/(\text{m}^2\text{h})$ . The advantage of the lower investment costs per  $\text{m}^2$  membrane surface can therefore not be exploited.

These results were acquired during the presented trials filtering secondary effluent of a municipal wastewater treatment plant ( $\text{TS} < 10 \text{ mg}/\text{L}$ ) and do not reflect the feasibility of the 0.9 mm modules for processes with different water sources. Recommendation for the plant design is therefore a high flux leading to a high recovery (1 stage) with capillary inner diameters of 1.5 mm. Alternatively when high recovery rates are not required a design with lower fluxes and a capillary inner diameter of 0.9 mm could be considered.

### 3.2.2 Results Statistical trial planning

The software tool MODDE® was used to plan and evaluate trial phase 1 with a statistical trial approach. The recorded data and the defined response were discussed in section 2.5.2. Since trial phase 1 was aborted for the UF1a (0.9 mm module) the results presented hereafter are for UF2a (1.5 mm module).

After data collection the influence of the examined factors were evaluated and since an interaction model was chosen in the trial design, the different factors were tested as multiplication terms in the model. A **multi linear regression (MLR)** model was defined and used for interpolation predicting the fouling rates according to the chosen operation strategy. Following factors were used to define the model:

1. Time of filtration
2. Flux
3. Coagulant dosage
4. Coagulant dosage \* Flux

During this trial phase a conservative CEB strategy with two steps, caustic followed by acidic, was applied with 1 h soaking time each. As mentioned in section 2.3 a CIP was carried out when the permeability@20 °C fell below  $300 \text{ L}/(\text{m}^2\text{hbar})$  leading to comparably short CIP intervals. This permeability constraint was defined to assure a correct interpretation of each experimental run.

The **backwash time** was defined as one of the controllable factors, because this parameter has a major impact on the recovery as well as the fouling rate. A regular hydraulic backwash is necessary and the optimum of the backwash strategy is defined within the frequency (filtration time) and the duration (backwash time). The outer boundaries, no backwash or high frequent backwash, are physically obsolete. Using the experience of previously conducted experiments the range for a filtration cycle was set to 30 - 60 min and the backwash time was varied between 35 - 55 s. The long filtration time of 60 min marked the upper boundary and when applying the upper limit for the flux, no stable operation was expected. While testing the controllable factors the backwash time showed a neglectable impact on the total fouling rate. What is more important is the first impulse through the membrane. Therefore it is necessary to reach the targeted backwash flux instantly. The retained solids and the foulants loosened by the backwash need to be flushed out of the module and the piping system, therefore a minimal backwash time is necessary. Considering a dead-volume of approximately 20 L for the membrane module the shortest tested backwash time (35 s with  $250 \text{ L}/(\text{m}^2\text{h})$ ) equals 5 times the module volume (Dizzer 1.5). A sufficient backwash effect was stated as long as the  $\text{TMP}_{\text{Start}}$ -ratio lay within 0.95 to 1.05 see section 2.4.

The results are visualized in Figure 35. The total fouling rate is shown according to the chosen model parameters: flux, filtration time and coagulant dosage. The colour represents the increasing fouling rate from blue to red. Following assumptions are generally accepted for membrane filtration processes and can now be expressed with an **explicit model** for WWTP Ruhleben secondary effluent:

- High flux leads to a high fouling rate
- Long filtration time leads to a high fouling rate
- Increased coagulation reduces the fouling rate

For the latter one it is noteworthy that even with a coagulant dosage of 12 mgFe/L, corresponding to approximately 30 mg/L of MLSS introduced by coagulation plus the MLSS concentration present in secondary effluent no negative effect was recorded. Nonetheless, high coagulant concentration has a twofold negative impact on the operation costs, due to the increased purchase and sludge disposal costs. Therefore 12 mgFe/L were chosen as the upper boundary.

With the prediction by the model the CIP interval can be determined (see Table 12) and the requirements for a full scale filtration plant could be specified. Within OXERAM the screening results were used to determine the operation window.

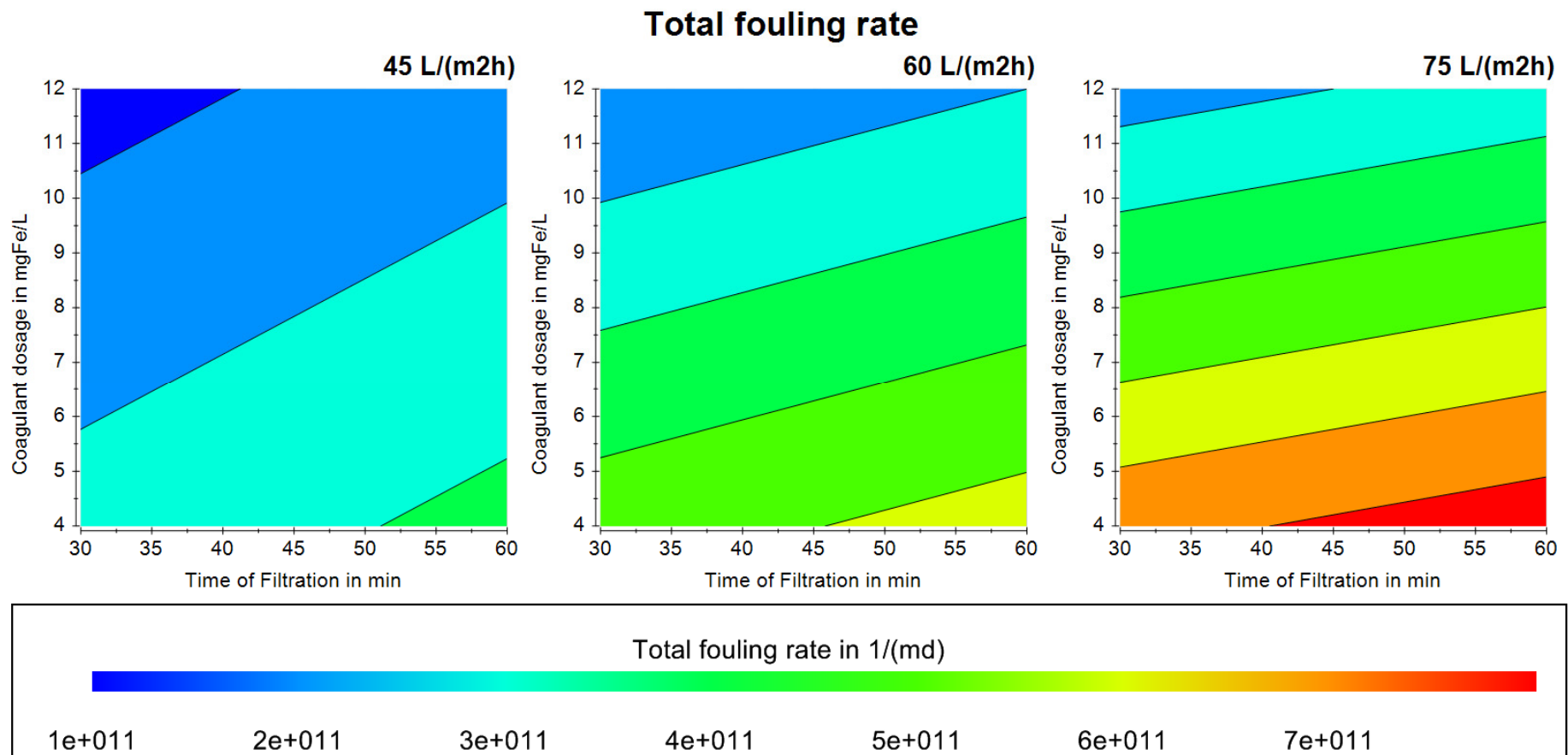

Figure 35: Results statistical trial planning polymeric membranes – Total fouling rate prediction

A model definition for the irreversible fouling rate has also been executed, but the results were not satisfying. The model was not robust, thus the results were too broad. This can be explained by the short trial duration of 3 - 4 days. The irreversible fouling is a long term phenomenon and can only be studied in long term runs. The irreversible fouling rate is the highest during the first days after a CIP. The results acquired with this model represented therefore a “worst case” scenario.

**Table 12: CIP frequency in relation to the fouling rate – according to results of the statistical trial plan**

Flux in L/(m <sup>2</sup> h)	Coagulant dosage in mgFe/L	Time of filtration min	Max TMP in bar	Total fouling rate in 1/m/d	CIP frequency in d
45	8	60	0.8	2.4E11	~22
60	8	60	0.8	3.7E11	~12
75	8	60	0.8	4.8E11	~6

The recovery and the installed membrane surface are decisive cost drivers and therefore an intensive operation strategy seems to be economically favorable. An adapted and optimized cleaning strategy is a precondition for a reliable operation under this high surface loading. Since the trial runs with 75 L/(m<sup>2</sup>h) and 60 min filtration time were feasible and achieved the required 95 % of recovery, further tests with this set up were carried out. The CIP interval calculated by the defined model is with 7 d comparably short and the down time of the module stacks and the increased working hours had to be evaluated critically. Due to the optimization of the cleaning strategy, see section 3.2.3, the intensive operation with 75 L/(m<sup>2</sup>h) over 60 min was possible with a significant lower fouling rate than predicted.

### 3.2.3 Cleaning strategy

#### 3.2.3.1 Chemical Enhanced Backwash

The importance of an optimized cleaning strategy has been discussed previously and during trial phase 1 a reliable, but comparably intensive CEB cleaning strategy was applied. CEB was carried out every day in two steps, caustic followed by acidic, with a soaking time of 1 h each. Additionally a chloride (200 ppm) step was carried out once a week. Preliminary calculations showed the immense impact of the daily cleanings on the operational costs and therefore the necessity of these cleanings was verified. Three test runs with the same operational set up were conducted for one week each. The experiments took place within three weeks and the water quality did not change notably, thus a direct comparison is valid. Table 13 shows the operational results for these runs.

**Table 13: CEB validation**

CEB strategy	Daily	Every other day	No CEB
Recovery	~95 %	~90 %	~85 %
Operation	75 L/(m <sup>2</sup> h); 60 min.; 12 mgFe/L; 35 s BW		

The total fouling resistance for the test run “no CEB” is shown in Figure 36.

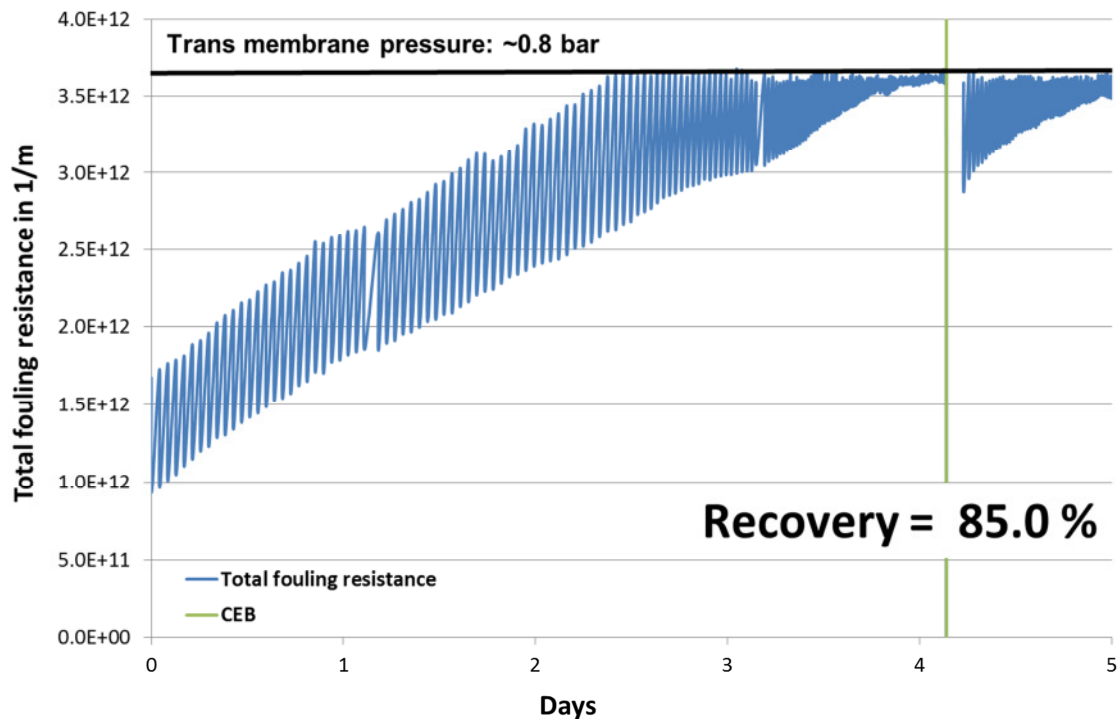
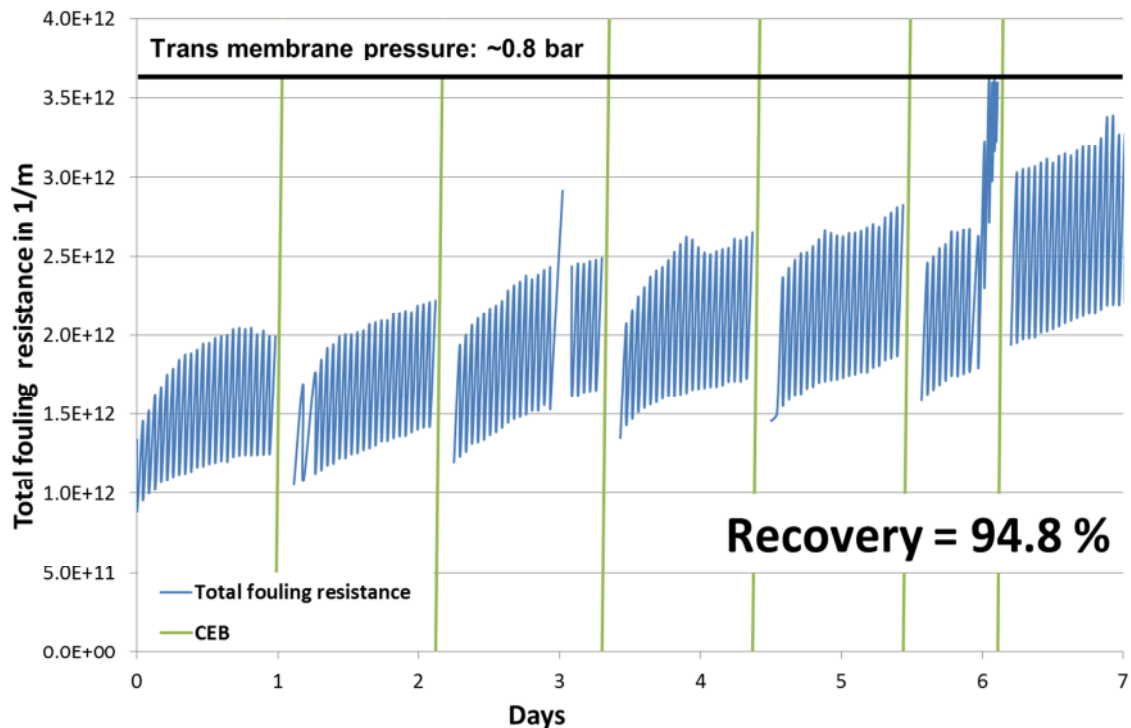

Figure 36: CEB validation – without CEB

The total fouling resistance increases constantly and the maximum trans-membrane pressure of 0.8 bar is reached within a few days. Once the filtration cycle is shortened the necessary recovery of 95 % cannot be achieved since the filtration cycle is reduced to few minutes, thus no filtrate is produced anymore.

In Figure 37 the test run with a daily CEB is displayed and the fouling resistance increased slower compared to the test run without CEB. Therefore the filtration cycle was carried out as planned and the recovery was ~ 95 %. These experiments showed the benefit of a daily CEB. It also shows another effect, indicating the superior operation with a planned CEB: At the end of day six the maximum trans-membrane pressure was reached for few filtrations cycles. This could have happened due to degraded raw water quality or malfunction of coagulant dosing. Once the CEB was carried automatically the resistance was lowered and the filtration lasted 1 hour again. This operation robustness illustrates clearly the advantage of a regular CEB over a non CEB approach.



**Figure 37: CEB validation – daily CEB**

Since the positive impact has been proven by these test runs and the strong influence on the recovery was shown, an optimization addressing the soaking time and the used chemicals was carried out. The evaluation of each CEB combination was done calculating the regeneration according to the method described in section 2.4.3. The CEB effect is not as clear as the CIP effect when 70 – 90 % of the initial permeability can be restored. During undisturbed operation, the CEB effect is between 0 - 10 %. Nevertheless, the CEB validation tests showed clearly the long term necessity of CEBs. Due to the enhanced water hardness in Berlin, precipitation of calcite might occur during the caustic cleaning step and dissolving precipitates by acid is necessary. Optimizing the CEB strategy targeted a compromise between CEB-frequency, soaking time, concentrations, applied chemicals and operational constraints.

Finally, the usage of NaOH and NaOCl was only applied once a week and the daily CEB was only carried out with H<sub>2</sub>SO<sub>4</sub>. This strategy showed to be sufficient to control fouling by biopolymers and other organic matter. The one-step approach saves chemicals and increases the productivity, due to the lower down-time for each CEB.

### 3.2.3.2 Cleaning in Place interval

The CIP requirements influence the design and cost estimation of a tertiary filtration step in different ways:

- During the CIP a membrane rack is out of operation.
- A short CIP interval leads to a high usage of cleaning detergents and heating energy.
- The lifetime of the membrane module depends on the total contact time with the cleaning agents, thus frequent CIP might increase re-investment cost.

Full scale experiences with membranes as the tertiary treatment step are limited and most of these plants were commissioned within the last decade. Therefore the average lifetime is difficult to predict, especially since the transfer of cleaning needs (thus the contact time) cannot be transferred easily from one WWTP to another. Within trial phase 1 the permeability constraint for the MODDE trials (see section 2.4.2) led to many CIPs. The total fouling rate estimated by the model predicted a short CIP interval when applying an intensive operation strategy. Therefore a medium flux of 60 L/(m<sup>2</sup>h) was used to start trial phase 2. As discussed in section 3.2.1 the total fouling resistance was in an acceptable range after 3 weeks of operation and the flux was increased to 75 L/(m<sup>2</sup>h) with 60 min of filtration assuring a recovery of 95 %. Aborting the trials with the 0.9 mm module (UF1b) the free module socket of treatment line 1 was used to install another 1.5 mm module (UF1c) which was operated in parallel with the same operational set up except for the coagulant, where Alum (3.81 mgAl/L) was used. A CIP was furthermore only carried out, when the trans-membrane pressure exceeded 0.8 bar. During the following long term operation a CIP was not necessary for both treatment lines for more than three months; see Figure 39 and Figure 40.

In trial phase 1 an intensive and therefore reliable cleaning protocol was applied. The used membrane cleaning detergent MemX® is comparably expensive and no long term experiences on the impact of membrane ageing has been published so far, therefore it is recommended to use this detergent only when heavy fouling has occurred. In order to estimate the costs for the CIPs, MemX® is planned to be used once a year, where the remaining cleanings are carried out with NaOH (pH>12) instead of MemX®.

### **3.2.4 Economic evaluation of operation strategy – polymeric membranes**

Due to the constraint of a maximum of 5 % backwash water return two design schemes for a filtration step within WWTP Ruhleben are possible:

- Two stage filtration, where the first stage achieves a recovery of 80 – 90 % with a moderate flux followed by a second stage treating the return flow. The combined recovery exceeds 95 %
- One stage filtration achieving a recovery ≥ 95 % by applying an intensive operation strategy with high fluxes and an optimized cleaning schedule

Figure 38 shows a sensitivity analysis for the annual costs of a filtration stage at WWTP Ruhleben. The assumptions used for this economic evaluation are given in detail in D6.2 by Remy 2013. For the two stage design 60 L/(m<sup>2</sup>h) were chosen as the design flux for the first stage and 30 L/(m<sup>2</sup>h) for the second, due to the high amount of suspended solids separated by the first stage (contained by SE and created by coagulation). In order to show the impact of the applied coagulant dosage on the overall annual costs the results for 4 and 8 mgFe/L are shown for both operation strategies. The CIP interval was also varied between 15 – 90 d for the one stage approach and it is shown, that due to the usage of standard chemicals the CIP frequency is not a major cost driver. The usage of the special cleaner MemX® is planned to be used once a year in case heavy fouling occurred.



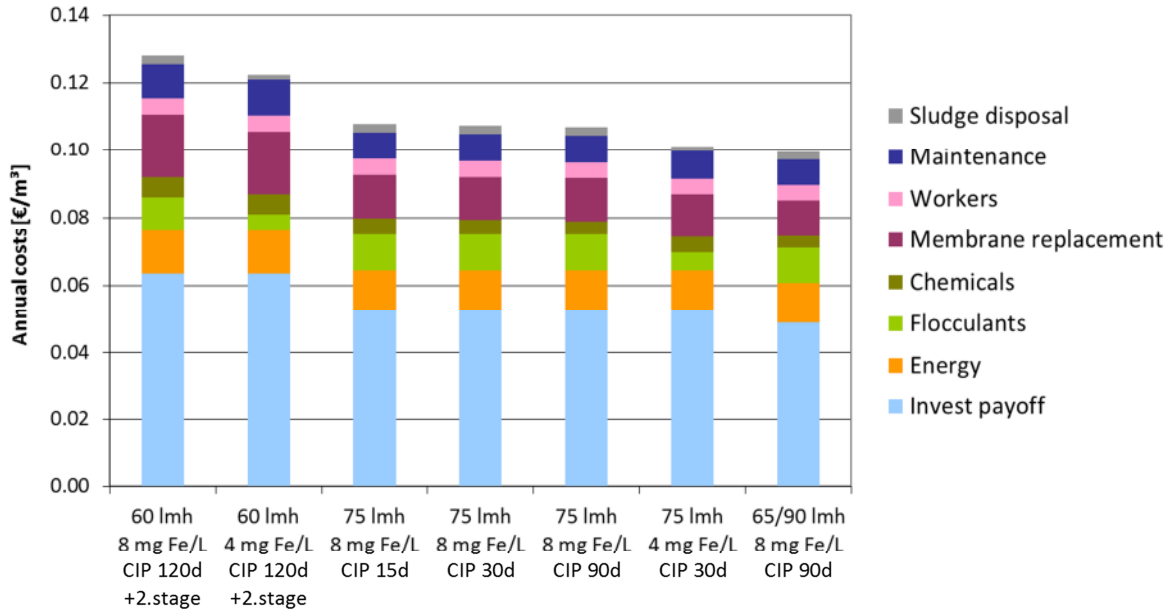

**Figure 38: Economic comparison of operation strategy – polymeric membranes**

The invest/re-invest costs for the 2<sup>nd</sup> stage, in particular the membrane modules, outnumbers the costs for the shorter CIP interval of the one stage design and therefore the intensive operation strategy was chosen to be evaluated further, see section 3.2.5. The last calculation is based on a variable flux strategy, given the precondition that a recovery of 95 % has to be achieved only during the dry-weather peak. This has been tested in short term during OXERAM and is further discussed in section 3.2.6.

### 3.2.5 Trial phase 2: Long term operation (coagulant comparison)

Due the explicit impact of the recovery on the capital costs (invest and reinvest) an intensive operation design was chosen. The screening period showed a possible operation with 75 L/(m<sup>2</sup>h), 8 mgFe/L (respectively 3.81 mgAl/L) and 60 min of filtration. These parameters were used to start the demonstration phase in order to proof a robust operation and to evaluate the predicted fouling rates.

**Table 14: Long term validation – operational set up**

Flux	Time of filtration	Coagulant dosage	Backwash	CEB strategy
75 L/(m <sup>2</sup> h)	60 minutes (95 % recovery)	8 mgFe/L or 3.81 mgAl/L	40 s@250 L/(m <sup>2</sup> h)	Daily: H <sub>2</sub> SO <sub>4</sub> (pH<2 for 1 h) Weekly: NaOCl (200 ppm Cl for 1 h)

Figure 39 shows the total fouling resistance over three months for UF2b operated with Fe as the coagulant. The maximum TMP of 0.8 bar lies in a resistance range of  $3.4 \cdot 10^{12} - 3.9 \cdot 10^{12} \text{ m}^{-1}$  (@75 L/(m<sup>2</sup>h)). This range was only reached for few days (not visible in this resolution) and regular hydraulic backwashes and/or CEBs were able to lower the total fouling resistance to a level below  $2.0 \cdot 10^{12} \text{ m}^{-1}$ . These incidents can be explained by short term effects such as poor feed water quality due to heavy rain incidents or malfunctions of the upstream process steps.

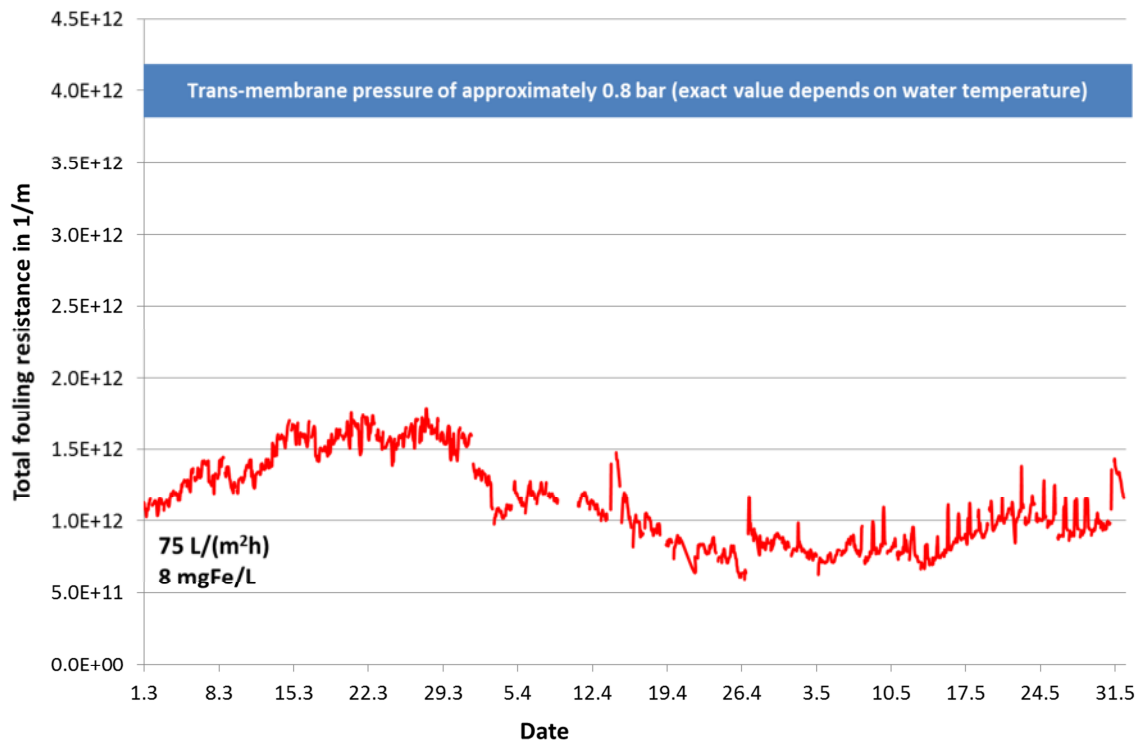

**Figure 39: Long term demonstration - Fe as coagulant**

The results acquired with Al as the coagulant showed a similar behavior and over three months the total fouling resistance remained below the critical value, see Figure 40. This long validation period was necessary to show the robustness of the process and to verify the assumption made for the plant design and costs calculations.

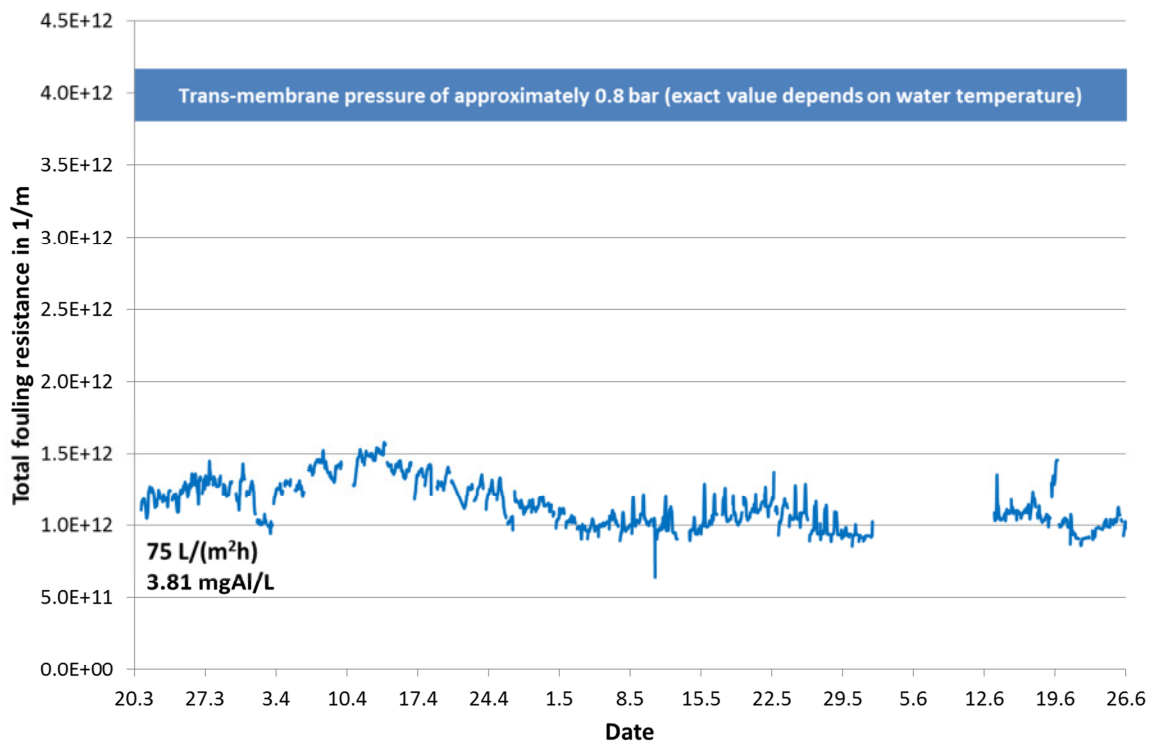

**Figure 40: Long term demonstration - Al as coagulant**

### 3.2.6 Variable flux trial

Provided that the recovery constraint of 95 % is only mandatory during the dry weather peak flow a dynamic flow approach can be used designing a tertiary filtration step. Following benefits are expected:

- Higher design flux leads to lower capital/reinvest costs
- Lower fluxes during low flow periods result in lower fouling rates
- Enhanced operation robustness and flexibility

In order to test these hypothesis a test run with two different fluxes per day was carried out for 3 weeks. Two daily flux profiles were chosen treating in 24 h approximately the same amount of water compared to a 75 L/(m<sup>2</sup>h) constant flux operation, see Table 15. The daily profile (65 L/(m<sup>2</sup>h) at night and 90 L/(m<sup>2</sup>h) during peak flow) is quite representative for a dry weather daily profile (membrane units to be designed for the dry weather peak flow).

**Table 15: Key parameter for different flux strategies**

	Flux in L/(m <sup>2</sup> h) 8 mgFe/L	Duration in h	Treated water in m <sup>3</sup> /d and module
<b>Constant flux</b>	75	24	68.4
<b>Variable flux</b>	90	4	61.7
	65	20	

The daily acidic CEB was scheduled right after the 4 h of high flux operation. This way the increased fouling load deposited on the membrane surface is treated directly after operation. Figure 41 shows the total fouling resistance during these tests.

After a slight increase in the beginning of this trial run, the fouling resistance is constant and the corresponding fouling rates are low over 3 weeks. This shows the capability of a membrane filtration step to be operated with a variable flux.

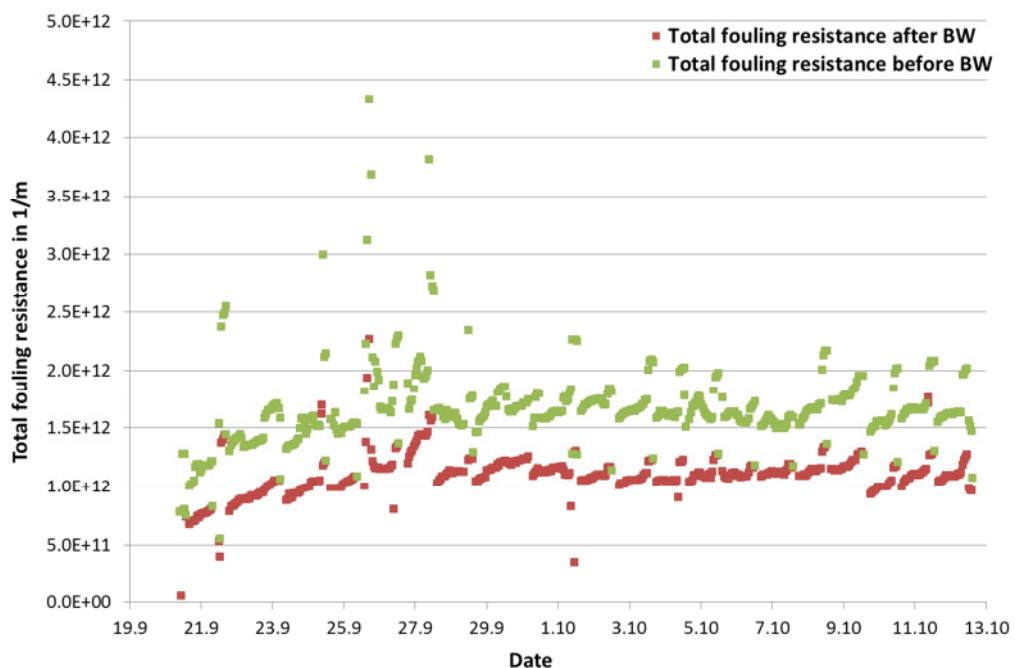

**Figure 41: Total fouling resistance - variable flux trials**

The total fouling rate over the three weeks of operation was with  $6.38E+10 \text{ m}^{-1}\text{d}^{-1}$  in an acceptable range and the CIP interval can be estimated with  $\sim 60 \text{ d}$ . Since the CIP interval is calculated through the total fouling rate using the low resistance at the start of the operation the fouling rate could be overestimated. Evaluating the results for the latter two weeks of the experiment where the resistance stays constant a longer CIP interval might be assumed. Nevertheless no negative effect due to the increased load of foulants during the peak flow was recorded. In Table 16 the potential savings in membrane surface is given. The dry weather peak flow of  $4.5 \text{ m}^3/\text{s}$  is used for the calculation.

**Table 16: Full scale design with constant/variable flux operation - dry weather peak flow  $4.5 \text{ m}^3/\text{s}$**

	<b>Design with constant flux with <math>75 \text{ L}/(\text{m}^2\text{h})</math></b>	<b>Design with variable flux with <math>90 \text{ L}/(\text{m}^2\text{h})</math>@peak flow</b>
<b>Recovery</b>	$\sim 95 \%$	min. $95 \%$ @ peak flow
<b>Required membrane surface</b>	$\sim 230,400 \text{ m}^2$	$\sim 192,000 \text{ m}^2$
<b>Number of membrane modules (1.5 mm)</b>	5,760	4,800
<b>Saving in modules</b>		<b>17 %</b>

It has to be kept in mind that during periods of lower fluxes the recovery decreases. The extra amount of backwash water has to be treated within the WWTP and causes additional costs. An enhanced control scheme has to be implemented using the predicted inflow to the WWTP and the current state of the membranes (through TMP/resistance calculation) to adapt the CEB strategy. Also a long term validation was not performed during OXERAM and should be considered evaluating the effects on the cleaning needs.

### 3.2.7 Operation with ozone

The OXERAM project targeted on the optimization of state of the art membrane processes for tertiary treatment and the evaluation of the beneficial effects of pre-ozonation on membrane filtration behaviour. The organic membranes used in this study were made of PES and therefore non ozone resistant. Two further measures were implemented to protect the membrane from dissolved ozone in case the retention/reaction time turned out to be insufficient:

1. Online measurement of dissolved ozone coupled with the membrane feed pump
2. Dosage of Sodium-bisulfite ( $\text{NaHSO}_3$ ) for instant destruction of residual ozone

The retention/reaction time within the ozone reactors was with minimal 15 min long enough to allow complete reaction, considering the rich reactants present in the treated wastewater. Nevertheless due to the deceleration of the reaction rate a minimum of residual ozone can be present.

The installed online measurement was not able to produce reliable values; therefore Sodium-bisulfite ( $5 \text{ mgNaHSO}_3/\text{L}$ ) was permanently dosed when ozone doses higher than  $3 \text{ mgO}_3/\text{L}$  were applied.

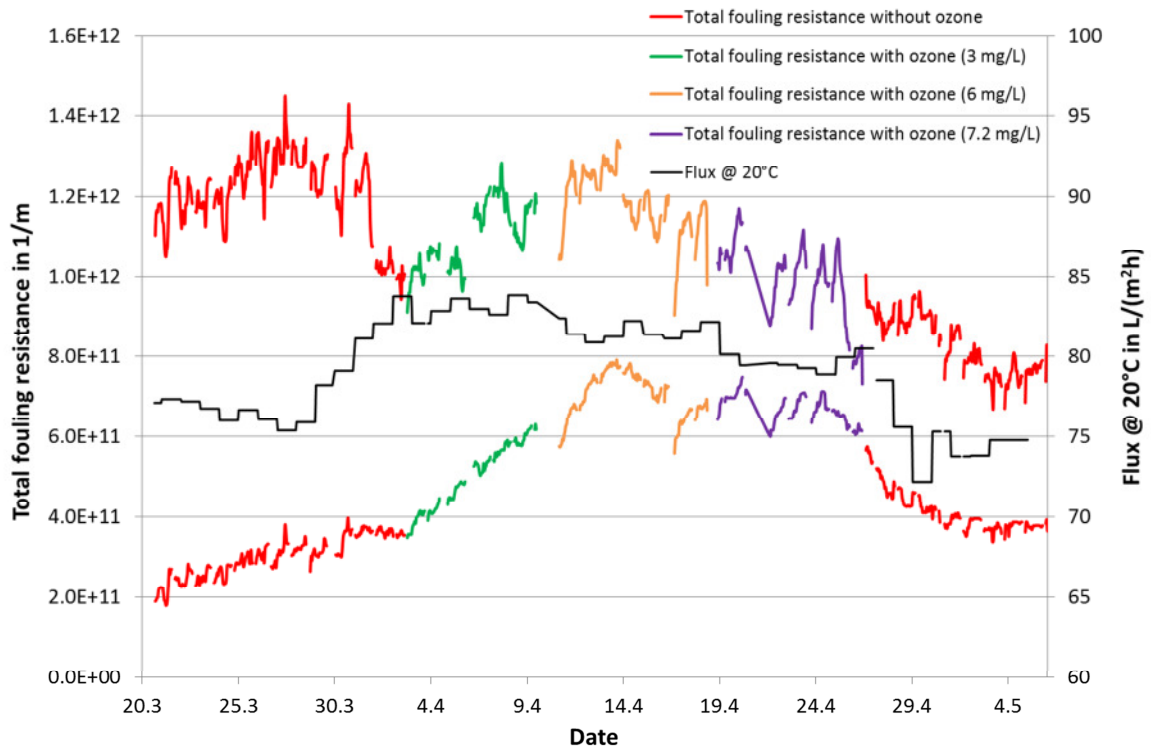

**Figure 42: Operation with and without ozone – PES ultrafiltration; Al as coagulant**

Figure 42 shows the fouling resistance for the operation with and without ozone. The results for the treatment line 1 with 3.81 mgAl/L are displayed. The ozone dose was gradually increased from 3 to 6 and 7.2 mg/L ozone. This complies with a specific ozone dose of 0.19 to 0.5 and 0.72 mgO<sub>3</sub>/mgDOC for these experiments. The lab scale results acquired by Godehardt et al. 2013 are confirmed by the pilot trials:

- The total fouling resistance is lowered smoothly
- The “irreversible” fouling resistance rises when ozone is applied

Due to the constant flux operation (75 L/(m<sup>2</sup>h)) and changing temperature the flux was corrected to 20°C. This corrected flux is displayed by the black curve and shows the gradual change of temperature between 16° and 21°C, respectively 73 to 84 L/(m<sup>2</sup>h)@20°C.

The fouling resistance after a backwash is defined as the “irreversible” fouling resistance that cannot be removed by backwash and is only partially controlled by the CEB. Focusing on this irreversible share, the negative impact of ozone can be seen in the beginning and the end of the ozone trials.

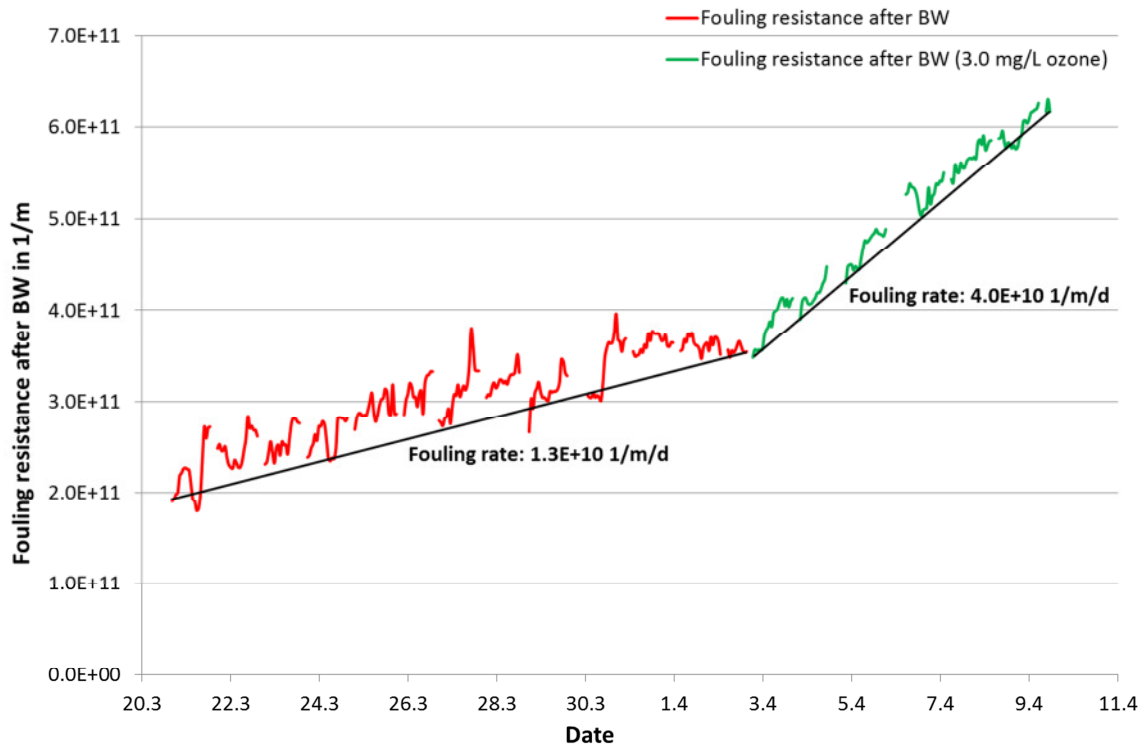

**Figure 43: Fouling resistance and fouling rate with and without ozone – start ozone trials**

Figure 43 is giving the fouling resistance and rates during the operation with and without ozone. Applying 3.0 mgO<sub>3</sub>/L (0.19 mgO<sub>3</sub>/mgDOC) the “irreversible” fouling rate is tripled instantly.

The property to reduce the fouling resistance just by hydraulic backwash once ozonation is deactivated (Figure 44) suggests that the increased fouling resistance is not irreversible per definition. In Figure 44 the regeneration is shown and the fouling resistance after BW stabilizes at ~3.6E+11 m<sup>-1</sup>, approximately 50 % lower than with ozonized water. The reduction is linear over the following backwashes and the CEB does not have an enhanced effect. This proves the assumption that hydraulic backwash is sufficient for regeneration. The irreversible fouling rate recorded after the ozone trials is with 4.22E+09 1/m/d a magnitude lower than the fouling rate before the ozone trials. This can be explained with an increased fouling rate in the first weeks of commissioning of a new membrane module. This aging effect has to be considered comparing fouling rates of different operational periods, e.g. in commissioning or just after a CIP. The fouling rate alone does not give the information about the absolute value of the filtration resistance. Due to the pilot set-up, it was unfortunately not possible to operate one treatment line with and the other without ozone for direct comparison.

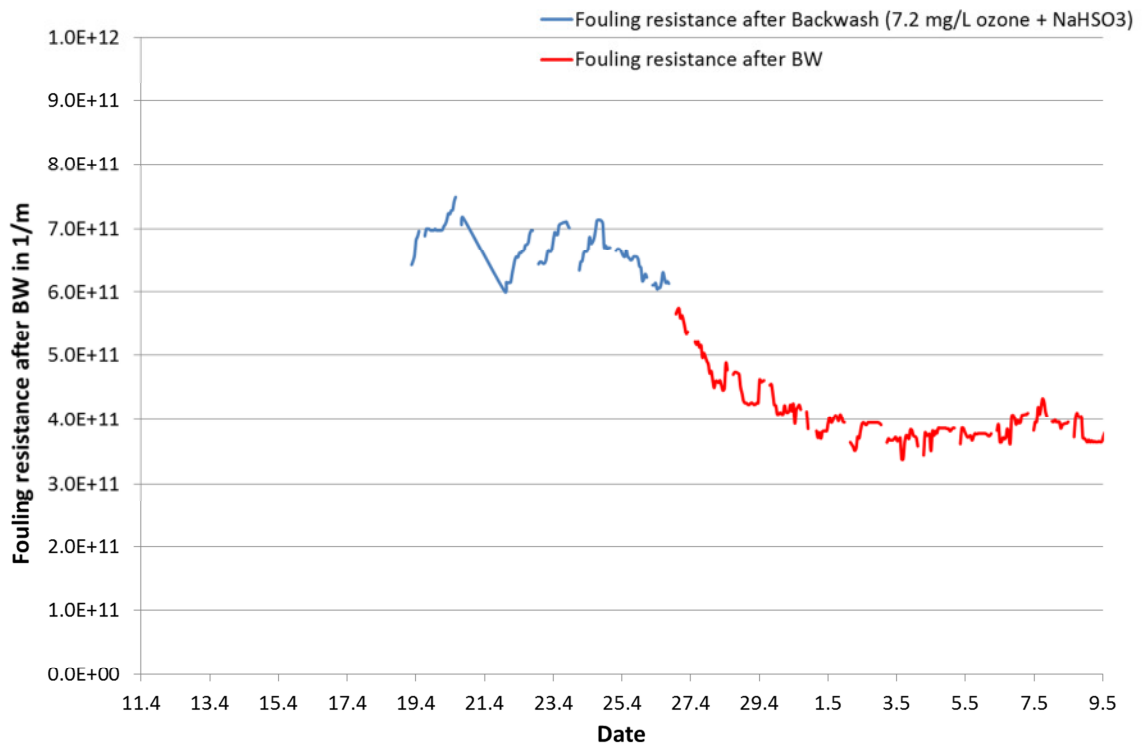

**Figure 44: Fouling resistance after backwash - end of ozone trials**

The beneficial effect of a lowered fouling resistance at the end of each filtration cycle and the resulting energy savings is diminished by the increased fouling resistance after the backwash. Comparing the mean TMPs for this operation period it can be stated, that there is no significant energy saving potential through ozonation, see Table 17.

**Table 17: Mean trans-membrane pressures with and without ozone – treatment line 2 (UF2b)**

	With ozone	Without ozone
<b>Mean trans-membrane pressure in bar</b>	<b>0.245</b>	<b>0.235</b>

**Summary**

- 1.5 mm inner capillary diameter recommended for intensive operation strategy and high recovery rate
- Recovery of 95 % demonstrated through intensive operation strategy (75 L/(m<sup>2</sup>h); 60 min of filtration; 40 s BW; 8 mgFe/L)
- The BW strategy was optimized: Daily acidic CEB, weekly caustic/chlorine CEB led to a CIP interval of 30 – 90 days
- No difference in filtration performance between tested coagulants (Fe, Al) during demonstration phase
- No saving through ozonation, due to increase of filtration resistance after BW
- Potential for variable flux strategy i.e. with design at peak flow with 90 L/(m<sup>2</sup>h) shown in short term trials
- Statistical trial planning is useful to find optimum operating point, but at least 2 week runs are advised

### 3.3 Ceramic membrane operation

Pre-ozonation was proven to enhance the operation of ceramic membranes significantly at other sites. Sustainable fluxes of 300 – 500 L/(m<sup>2</sup>h) were reported by Panglisch et al. 2010 treating surface water for drinking water production. These promising results needed to be tested with secondary effluent. In section 3.3.1 the results of trial phase 1 including trials with ozonized water are given. Critical flux and high flux experiments were conducted to identify a sustainable operation strategy, see section 3.3.1.2. The cleaning strategy is summarized in section 3.3.2. Trials to demonstrate the identified operation strategy were conducted in the end of the trial phase and are presented in section 3.3.3. An economical comparison against a full scale plant equipped with polymeric membranes operated with the suggested operational set up is presented in section 3.3.4.

#### 3.3.1 Trial phase 1

A model predicting the total fouling rate was specified in compliance to the model defined for the polymeric membranes. Due to the immense impact of ozonation on the fouling rate a relevant model predicting the fouling rate could not be validated. During the trials the fouling rate was always significantly lowered when ozone was applied. Interpreting the results after the 19 experimental runs no relevant model could be defined and predicting the fouling rate according to the pre-treatment was impossible. There was no clear differentiation between the medium (7.5 mgO<sub>3</sub>/L; ~0.6 mgO<sub>3</sub>/mgDOC) and the high dose (15 mgO<sub>3</sub>/L; ~1.17 mgO<sub>3</sub>/mgDOC) with respect to the total fouling rate. Due to the design of experiments the medium ozone dose was applied with the medium operational parameters, 90 L/(m<sup>2</sup>h) 8 mgFe/L 45 min, therefore a direct comparison with experimental runs operated with a different set up was not meaningful. Nevertheless, focusing on the fouling rates the positive impact of ozonation can be seen, as described below.

##### 3.3.1.1 Fouling rate evaluation

The factors for the experimental runs were varied as explained in section 2.5.3. This way experimental runs with/without ozone were carried out and since the feed water quality did not change explicitly the results can be compared directly.

Figure 45 shows the total fouling rates with and without ozone. Comparing the experimental pair 02 with 06 it can be stated that even though the flux was doubled, the fouling rate was reduced by half through ozonation. Considering the fact, that due to the doubled flux twice as much suspended solids and foulants are deposited on the membrane surface, this result shows the high potential for ozonation.



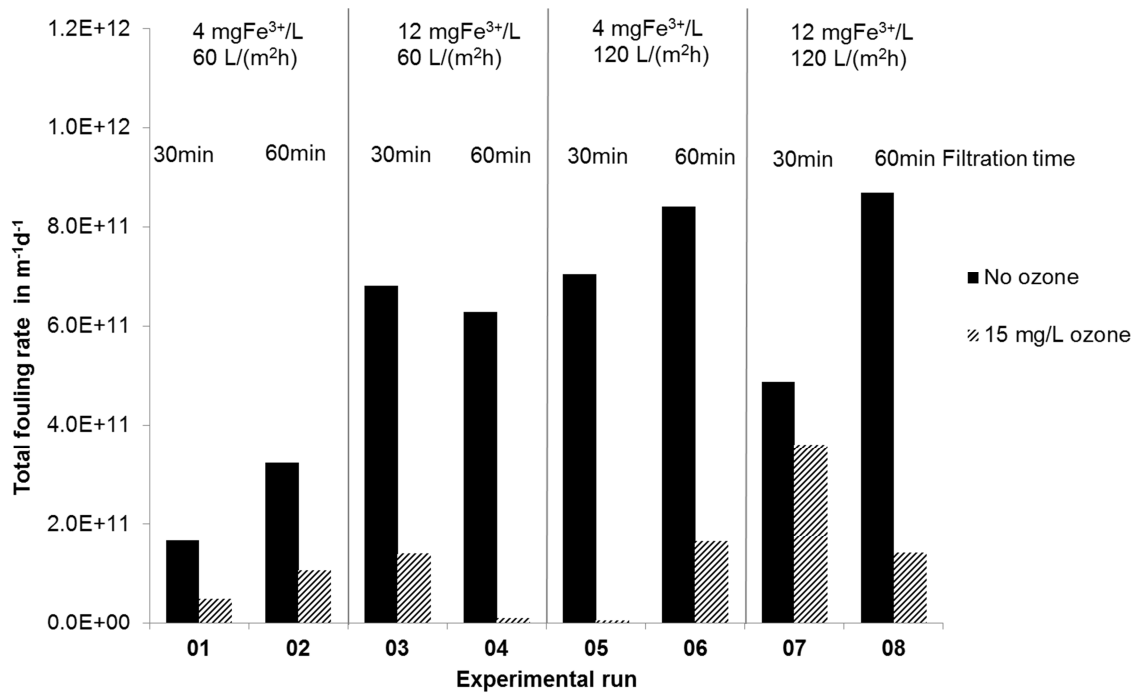

**Figure 45: Total fouling rates ceramic membrane - trial phase 1**

The ozone dose was with 15 mgO<sub>3</sub>/L (~1.17 mgO<sub>3</sub>/mgDOC) the upper limit and comparably high and dissolved ozone reached the membrane surface. The specific ozone dose and the retention time between ozonation and filtration unit determine the dissolved ozone concentration reaching the membrane surface. Figure 46 shows the dissolved ozone concentration along the water path and the sampling points at the pilot plants for this comparably high ozone dose. Due to the different applied fluxes (60 and 120 L/(m<sup>2</sup>h)), the hydraulic retention time within the membrane pilot (SP3 – SP5) varies between these sampling days. In both cases a dissolved ozone concentration of approximately 250 µgO<sub>3</sub>/L were measured just before the membrane module. The concentration of dissolved ozone in the filtrate was below the detection limit of 100 µgO<sub>3</sub>/L. This indicates the complete reaction of ozone on the membrane surface respectively with organic compounds on the membrane surface. The necessary ozone dose is a major cost driver for this process scheme and therefore its competitiveness depends highly on this parameter. The crucial question is whether dissolved ozone for a permanent cleaning is necessary in order to reduce the irreversible fouling rate. The irreversible fouling rate without ozone was in average 5 times higher compared to experimental runs with ozone (5.2 E11 m<sup>-1</sup>d<sup>-1</sup> vs. 0.96 E11 m<sup>-1</sup>d<sup>-1</sup>) regardless of the applied ozone dose. A further differentiation between the applied ozone doses and the resulting dissolved ozone concentration on the membrane surface is discussed in section 3.3.1.2.

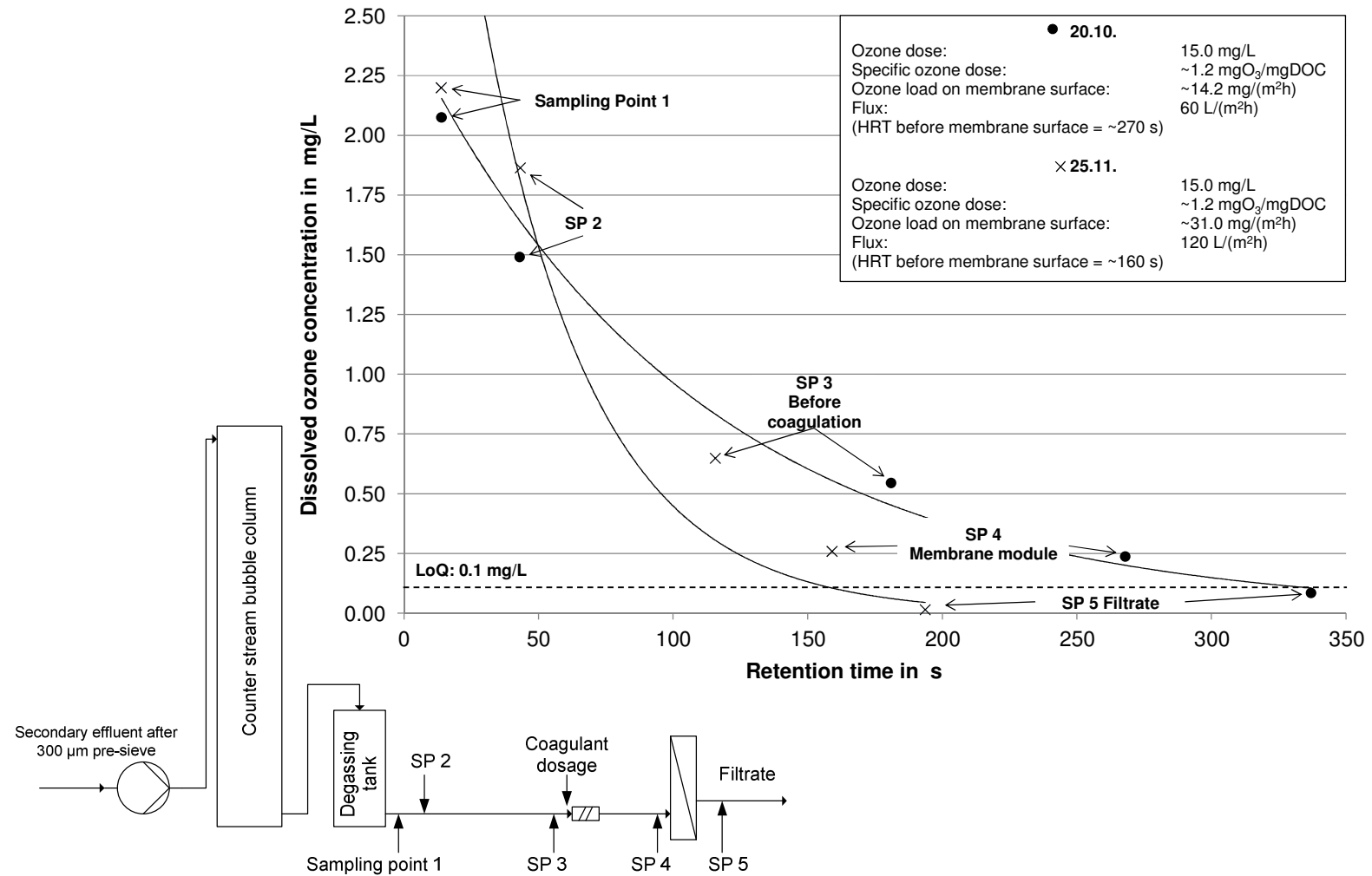

Figure 46: Dissolved ozone concentration along water path

### 3.3.1.2 Critical flux & High flux experiments

The beneficial effect of ozonation was shown in trial phase 1 by the reduction of the total and irreversible fouling rate. The highest flux tested during trial phase 1 was 120 L/(m<sup>2</sup>h) which could be operated for 7 d with an ozone dose of 15 mgO<sub>3</sub>/L. Two main questions had to be answered to evaluate the economic feasibility of this hybrid process:

- What is the sustainable flux?
- How much ozone is necessary?

In order to answer these question short term trials were conducted applying high fluxes, e.g. 150 – 175 – 200 L/(m<sup>2</sup>h) and different ozone dose (7.5 and 15 mgO<sub>3</sub>/L). Also tests following the critical flux approach were carried out.

A brief economic evaluation showed the need to enhance the flux above the tested 120 L/(m<sup>2</sup>h) to be competitive against the polymeric membranes, see section 3.3.4. A flux of 200 L/(m<sup>2</sup>h) and an ozone dose of 15 mgO<sub>3</sub>/L were chosen to start these experiments. During this test run dissolved ozone concentrations higher than 1.0 mgO<sub>3</sub>/L were measured directly before the membrane module. But even this high load of dissolved ozone did not prevent the membrane from rapid blocking. The flux was lowered to 150 L/(m<sup>2</sup>h) and the operation stabilized for few days. Applying the medium ozone dose of 7.5 mgO<sub>3</sub>/L the operation with 200 L/(m<sup>2</sup>h) was again not possible and the operation with 150 L/(m<sup>2</sup>h) was stable at a higher resistance, see Figure 47. During the test runs with 7.5 mgO<sub>3</sub>/L the specific ozone dose was ~0.58 mgO<sub>3</sub>/mgDOC while a specific ozone dose above 1.0 mgO<sub>3</sub>/mgDOC was applied with 15 mgO<sub>3</sub>/L.

The experiments with periodically high ozone doses leading to dissolved ozone on the membrane surface could not show a clear positive effect on the filtration performance. In Figure 47 experiments with high fluxes and high ozone doses are presented confirming the limited flux enhancing effect of dissolved ozone in processes with secondary effluent.

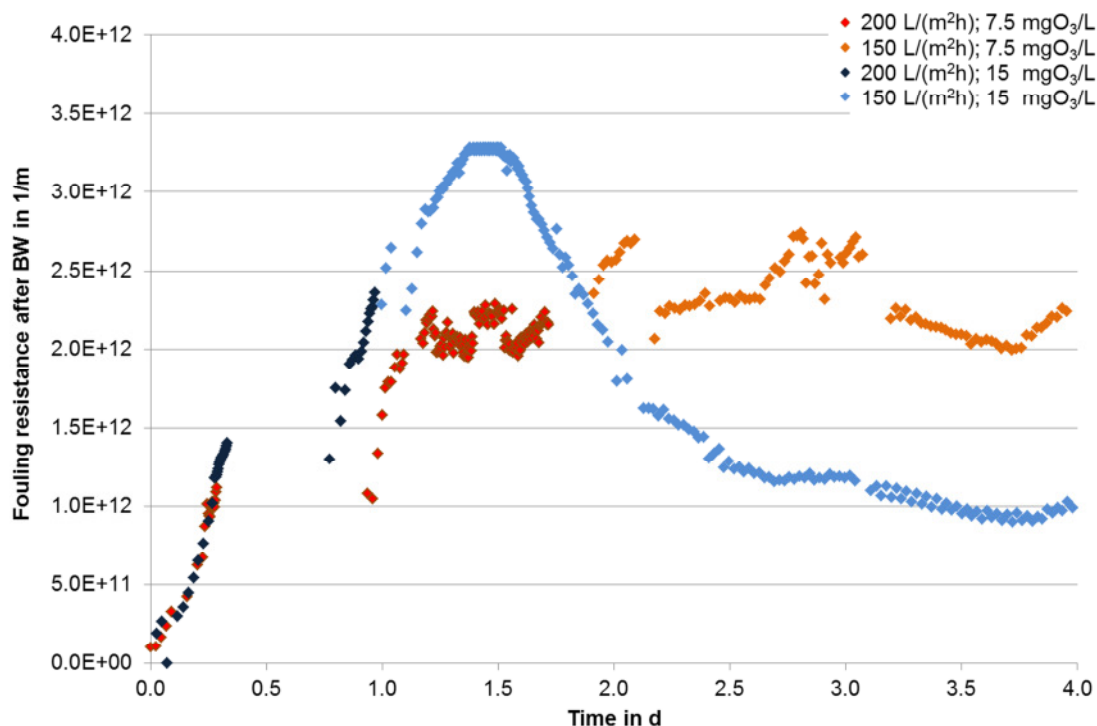

Figure 47: High flux experiments with 7.5 and 15 mgO<sub>3</sub>/L

The critical flux experiments were conducted with the three levels of ozone dose: 0 - 7.5 - 15 mg/L and increasing the flux from 50 L/(m<sup>2</sup>h) up to 250 L/(m<sup>2</sup>h) when possible. The flux was increased in steps of 10 L/(m<sup>2</sup>h) and each step lasted 11 min. followed by a Backwash. A CEB was carried out between the three trials. The following interpretation of the experiments was used to define the critical flux (according to De la Torre et al. 2009):

- The critical flux is reached when the slope of the TMP over time exceeds 4.5 mbar/min

**Table 18: Results critical flux experiments**

	No ozone 8 mgFe/L	7.5 mgO <sub>3</sub> /L 8 mgFe/L	15 mgO <sub>3</sub> /L 8 mgFe/L
Critical flux	112 L/(m <sup>2</sup> h)	140 L/(m <sup>2</sup> h)	150 L/(m <sup>2</sup> h)

Figure 48 shows the graphical evaluation of the experiments. The results confirm the first assumptions that a sustainable flux, which lies below the critical flux, without ozone for ceramic microfiltration lies in the range of 90 – 100 L/(m<sup>2</sup>h). The outcome for the ozonized water leads to the conclusion, that the sustainable flux is enhanced to 130 - 140 L/(m<sup>2</sup>h) by ozonation and that the higher ozone dose of 15 mgO<sub>3</sub>/L does not have a significant additional benefit over the medium ozone dose of 7.5 mgO<sub>3</sub>/L. Due to the margin of 10 L/(m<sup>2</sup>h) for each step, a precise differentiation between the 7.5 mgO<sub>3</sub>/L and 15 mgO<sub>3</sub>/L is difficult and it can be stated that the sustainable flux for both ozone doses lies in the same range.

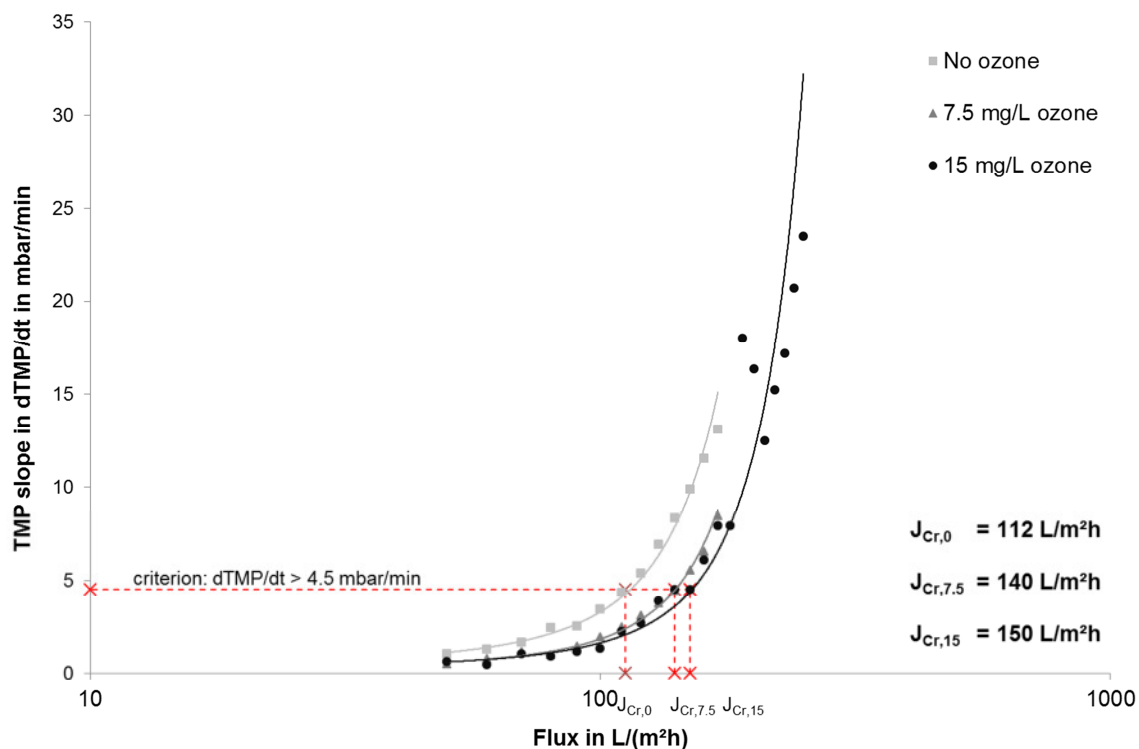

**Figure 48: Graphical interpretation of critical flux experiments**

Following conclusion can be drawn from these short term tests:

- Dissolved ozone did not have a significant beneficial impact on the filtration performance
- The sustainable flux lies in the range of 130-140 L/(m<sup>2</sup>h) when applying ozone
- A specific ozone dose above 0.6 mgO<sub>3</sub>/mgDOC is necessary to control the fouling potential

### 3.3.2 Cleaning strategy

The CEB procedure was adapted to the strategy defined with the polymeric membranes, thus an acidic (pH < 2) CEB was carried out every day with 1 h of soaking time. A weekly disinfection step with 200 ppm of Cl showed to be sufficient.

The CIP was carried out in 3 steps:

1. Acidic (4 g/L citric acid + HCl; pH~2); duration 2-4 h
2. 3000 ppm Cl (NaOCl pH<10); duration >12 h
3. Acidic (H<sub>2</sub>SO<sub>4</sub> pH~2); duration 1-2 h

During the first two steps the cleaning solution was circulated through the module cleaning the raw water and filtrate side. Additionally the temperature of the cleaning solution was raised up to 40 °C in the beginning of the first two cleaning steps. After soaking with NaOCl over night, circulation was applied for another 1 – 2 h. In compliance with the results for the polymeric membrane cleanings, this second period of circulation showed an enhanced cleaning effect. Generally the CIPs following this cleaning approach achieved a sufficient regeneration of 80 – 90 % of the initial permeability.

### 3.3.3 Long term demonstration

With the result acquired during trial phase 1 and the short term tests the following operational set up was proposed:

- 120 L/(m<sup>2</sup>h)
- 8 mgFe/L
- 9 mgO<sub>3</sub>/L (Specific ozone dose of ≥ 0.6 mgO<sub>3</sub>/mgDOC)
- 30 min of filtration
- Daily acidic CEB (pH<2); weekly CEB with 200 ppm Cl

This set up was a compromise unifying the needs reducing the required membrane surface and limiting the ozone production. The low amount of backwash water (50 L) per BW allows short filtration cycles. These shorter filtration cycles are beneficial as the higher fluxes compared to the polymeric membranes lead to a higher TSS load. The recovery is > 95 %. Due to instable operation during some of the previous trials following possible operational defects were monitored closely:

- Coagulant leaking into the piping system during an operational stop (e.g. CEB or refill of chemicals) causing membrane clogging by highly concentrated coagulant
- Insufficient backwash due to a low backwash-water amount (<< 50 L)

- Air in the top of the module caused either by a leaking pressured air valve or incomplete module filling after a BW/CEB
- Incomplete flush of the filtrate tank after CEB

The tests were started with a lower flux of 90 L/(m<sup>2</sup>h) in order to prove the operational reliability and a daily acidic (pH<2) CEB was carried out. Figure 49 shows the fouling resistance over 4 weeks indicating the flux increase after 11 d.

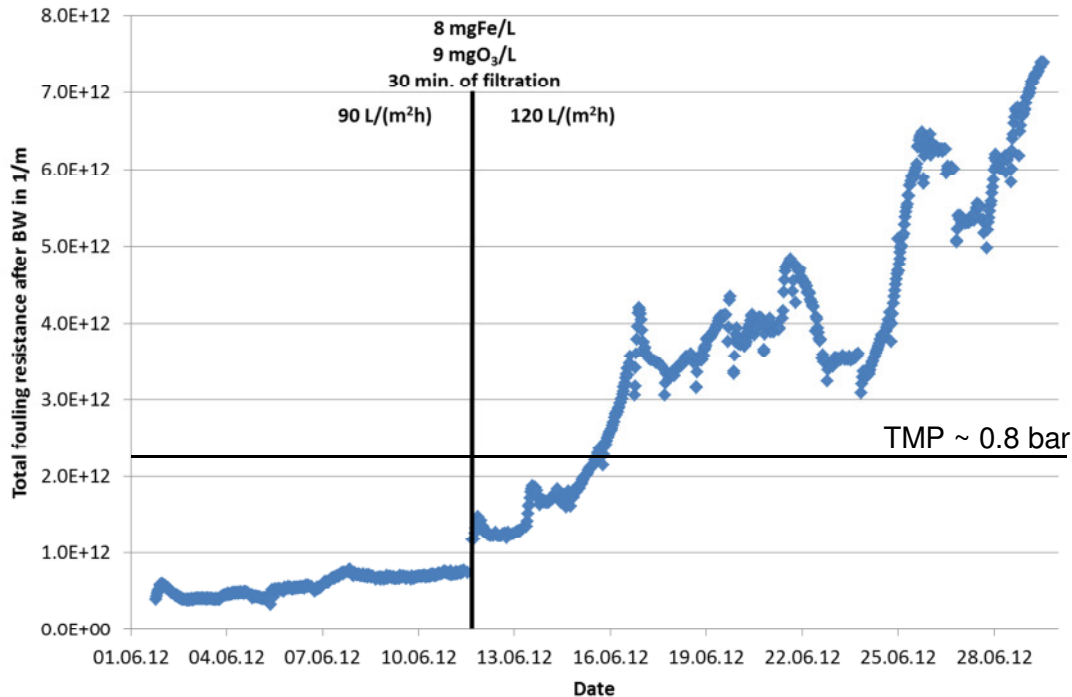

**Figure 49: Long term operation with 90 and 120 L/(m<sup>2</sup>h) – Ceramic membrane**

The evolution of the total fouling resistance with 90 L/(m<sup>2</sup>h) shows the expected low fouling rate when ozonation is applied (5.5E10 m<sup>-1</sup>d<sup>-1</sup>). When the flux was increased to 120 L/(m<sup>2</sup>h) the fouling resistance grew moderately for the first two days, which can be explained by the higher load of foulants on the membrane surface. After two days the total fouling resistance showed a rapid increase and the total fouling rate was with 2.37E11 m<sup>-1</sup>d<sup>-1</sup> four times higher than before. A technical malfunction of the earlier mentioned issues was not recognized. The BW and CEB regeneration was monitored and no extraordinary values were registered. The water quality in terms of turbidity and temperature did not show correlation with the pilot operation. Nevertheless, the high fouling rate and the rapid resistance increase within one day are not likely to be caused by regular fouling. Even with the high automation installed in the pilot plant the reason for this unsatisfying operation could not be determined without any doubt and a stable long term operation of the proposed process combination has still to be proven.

### 3.3.4 Economical trade off

The ozonation step causes additional costs for investment and operation. Therefore the beneficial effect of the ozonation needs to save on the other hand in terms of required membrane installation and energy. In order to define these required saving, the annual costs were calculated for the following cases (all with 8 mgFe/L):

- Ceramic membranes designed for 90 L/(m<sup>2</sup>h)

- Ceramic membranes designed for 120 L/(m<sup>2</sup>h) and 7.5 mgO<sub>3</sub>/L
- Ceramic membranes designed for 500 L/(m<sup>2</sup>h) and 7.5 mgO<sub>3</sub>/L
- Polymeric membranes designed for 75 L/(m<sup>2</sup>h)

Figure 50 gives the results. The case study with 500 L/(m<sup>2</sup>h) was chosen to display the required flux enhancing effect by ozonation to be competitive against the polymeric membranes without ozonation. The design for the polymeric membranes was done according to the results of OXERAM. This brief analysis emphasizes that the flux enhancing potential of ozonation combined with ceramic membranes is not sufficient to compete with conventional operation with polymeric membranes. It has to be kept in mind that during OXERAM it was not possible to operate 200 L/(m<sup>2</sup>h), even with a high ozone dose. The major reason why the combination of ozone and ceramic membranes for tertiary treatment at WWTP Ruhleben is not an economic alternative is the high concentration of DOC present in the secondary effluent. This leads to high ozone doses causing further costs for investment and operation, namely ozone generation and liquid oxygen.

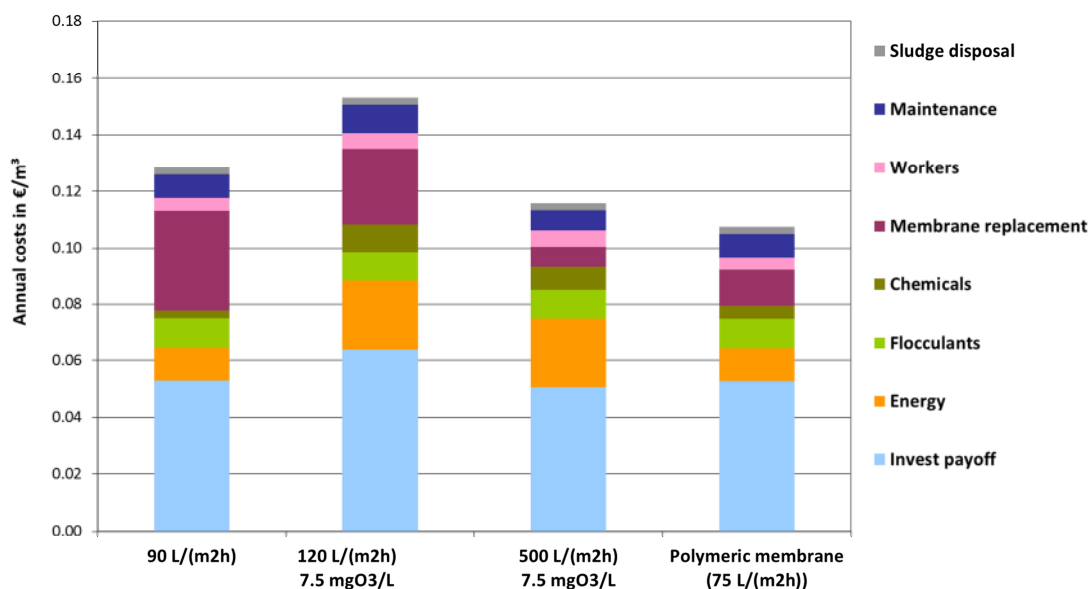

Figure 50: Economic trade off ceramic membrane

### Summary

- Potential of pre-ozonation was demonstrated: sustainable flux increased from 90 - 100 L/(m<sup>2</sup>h) to 130 -140 L/(m<sup>2</sup>h)
- Specific ozone dose of 0.6 – 0.8 mgO<sub>3</sub>/mgDOC sufficient, no need of residual ozone on the membrane
- Transformation of biopolymers into smaller compounds passing the MF membrane has been proven to be the major reason
- Long term stable performances with 120 L/(m<sup>2</sup>h) could not be demonstrated during OXERAM
- Economical evaluation showed that the higher sustainable flux is not sufficient to be competitive against polymeric membranes (flux ≥ 500 L/(m<sup>2</sup>h) necessary)
- High DOC concentration in WWTP Ruhleben secondary effluent causes high ozone demand, thus comparably high costs for ozone generation

## Chapter 4

### Conclusion

Membrane filtration of secondary effluent with micro- or ultrafiltration assures highest filtrate quality. Due to the complete retention of suspended solids phosphorus reduction and disinfection are achieved within one step. Coagulation prior filtration reduces the total phosphorus concentration down to 23 µg/L (mean value), which lies clearly below the targeted 50 µg/L. The project OXERAM targeted the optimization of state of the art membrane processes and the implementation of ozonation as an additional pre-treatment step. The acquired data was used for a robust plant design predicting the interaction between the different operation strategies and their effects on the annual costs, see Figure 51.

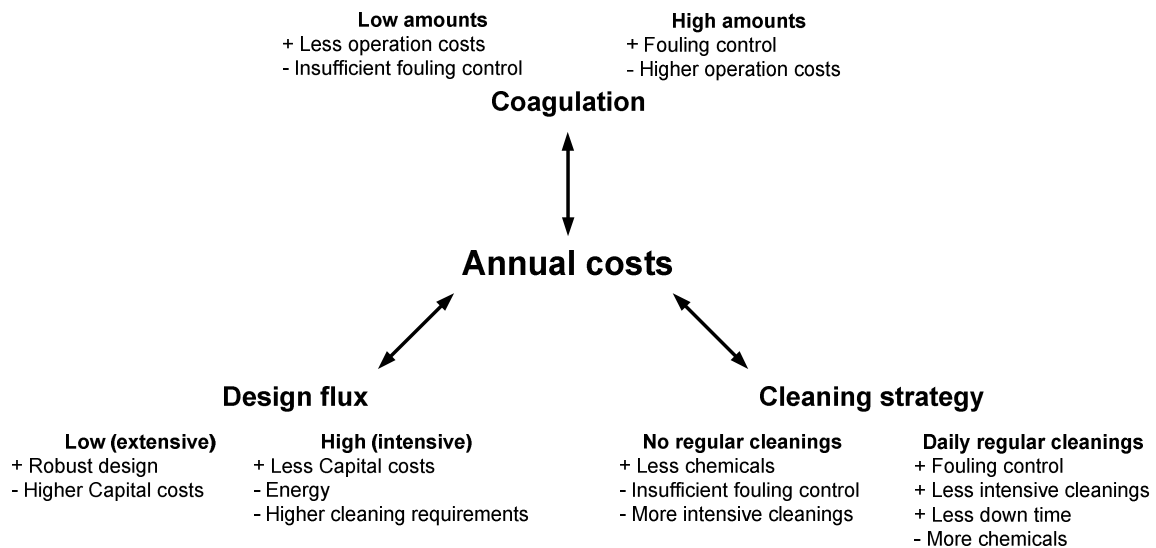

**Figure 51: Plant design constraints**

Two membrane materials have been tested, ceramic and polymeric, and the implementation of ozonation as a pre-treatment step was evaluated.

Section 4.1 summarizes the proposed operation for a tertiary treatment step through membrane filtration. *Statistical trial planning* was used defining the first experimental phase in order to reduce the number of experiments and highlighting the interaction between the operation factors. Section 4.2 gives an overview of this approach for pilot trials in water treatment. In section 4.3 the outcomes of the ozonation trials are presented.

#### 4.1 Proposed operation

In order to optimize membrane filtration as a tertiary treatment step for WWTP Ruhleben full scale membrane modules were operated in automated pilot plants. The following key figures were used for evaluation and helped to assess the tested set up:

- Fouling resistance
- Fouling rate



- Backwash regeneration
- Chemical Enhanced Backwash regeneration
- Cleaning In Place regeneration

These figures can be calculated with the standard process data, e.g. flow, trans-membrane pressure or temperature, and can be easily implemented in online control. Therefore a detailed picture of the state of the operated membranes is available and the operation can be planned in advance, e.g. cleaning needs or maintenance.

#### 4.1.1 Polymeric membrane

The polymeric membranes were operated with different operation set ups for 24 months and the operation strategy presented in Table 19 proved to assure a reliable and robust operation.

**Table 19: Proposed operation polymeric membranes – Tertiary treatment WWTP Ruhleben**

Operation parameter	
<b>Flux</b>	75 L/(m <sup>2</sup> h)
<b>Coagulant dosage</b>	8 mgFe/L
<b>Filtration cycle</b>	60 Minutes
<b>Backwash duration</b>	35 – 40 s
<b>Chemical Enhanced Backwash</b>	Daily acidic (H <sub>2</sub> SO <sub>4</sub> pH<2) weekly caustic (pH>12) and disinfection 200 ppm Cl
<b>Cleaning In Place strategy</b>	3 step: Citric acid (4 g/L + HCl; pH<2) NaOH (pH>12) Acidic (H <sub>2</sub> SO <sub>4</sub> pH<2)
<b>Cleaning In Place interval (predicted)</b>	30 – 90 days
<b>Recovery (predicted)</b>	95 % (no need of second stage)

Reliable filtration performance could be demonstrated with a constant flux of 75 L/(m<sup>2</sup>h) with a recovery rate of 95 %. Further potential for dry weather peak design with 90 L/(m<sup>2</sup>h) was investigated.

#### 4.1.2 Ceramic membrane

Ceramic membrane filtration is used in industrial wastewater treatment as well as in drinking water production due to its high mechanical and chemical resistance assuring highest filtrate quality and a long lifetime. The high fouling propensities of secondary effluent and the resulting lower sustainable fluxes lead to high membrane investment costs. Table 20 shows the recommended design criteria for the ceramic membrane with and without ozone. A specific ozone dose of 0.6 – 0.8 mgO<sub>3</sub>/mgDOC is required in order to reduce the amount of foulants attaching to the membrane surface. Due to operational issues these proposals were not be demonstrated in the long run. An economic evaluation showed that fluxes higher than 500 L/(m<sup>2</sup>h) are necessary to compete with the polymeric membranes without ozonation. The high DOC content of the secondary

effluent of the WWTP Ruhleben leads to high ozone production costs, what explains the limited economic potential of the combined process.

**Table 20: Proposed operation ceramic membranes – Tertiary treatment WWTP Ruhleben**

Operation parameter	Without ozone	With ozone
Flux	90 L/(m <sup>2</sup> h)	120 L/(m <sup>2</sup> h)
Ozone dose	/	6 - 9 mgO <sub>3</sub> /L
Specific ozone dose	/	0.6 – 0.8 mgO <sub>3</sub> /mgDOC
Coagulant dosage	8 mgFe/L	
Filtration cycle	45 min	30 min
Backwash duration	~60 s (5 bar; air/water scour)	
Chemical Enhanced Backwash	Daily acidic (H <sub>2</sub> SO <sub>4</sub> pH<2) weekly disinfection (200 ppm Cl)	
Cleaning In Place strategy	3 step: Citric acid (4 g/L + HCl; pH<2) NaOCl (3000 ppm Cl) Acidic (H <sub>2</sub> SO <sub>4</sub> ; pH<2)	
Cleaning In Place interval (predicted)	30 – 50 days	
Recovery (predicted)	>96 %	>96 %

## 4.2 Recommendation: How to use statistical trial planning in pilot scale

Statistical trial planning is a helpful tool in experimentation reducing the effort and giving more information of the tested system at the same time. Therefore it is a cost efficient approach in research and development. It has been applied in lab scale experiments by many working groups and through all scientific disciplines. Due to the increased computational possibilities statistical trial planning and modeling is recently combined in a single analysis step, giving the targeted results: A robust way of modeling a scientific/technical task.

The robustness of a calculated model depends on the precise quantification of the controllable and uncontrollable factors and minimization of disturbances. To fulfill this requirement for a sound experimentation and data analysis the controlled environment of a laboratory is beneficial. Nevertheless, when a process is basically understood and the possible disturbances can be measured and quantified correctly, statistical trial planning can be applied in pilot scale.

Within the OXERAM project the objective to apply statistical trial planning was to screen the experimental domain to find the most promising operational window. This objective can be used, when a new process step or technology is tested and the first experiments shall point out in what range the promising operational parameters can be expected. This objective can successfully be applied in pilot scale experiments.

Due to the experiences within OXERAM the following recommendations are given when applying statistical trial planning in pilot scale for water treatment processes with membrane technologies:

- Additional replicate runs, when uncontrollable factors, for instance feed water quality (e.g. turbidity), vary outside expected boundaries (e.g. disturbed operation in upstream processes)
- Clear definition and quality assurance of analysis methods
- The measurement campaign has to represent the trial duration
- Special interest has to be given to the definition of the responses
  - Within OXERAM the prediction of the total fouling rate overestimated the resistance increase due to the permeability constraint and the short trial duration. Indeed long term fouling is irreversible fouling, depending on the cleaning strategy (daily CEB). It is therefore recommended to plan trial duration of at least 10 – 14 days in order to not overestimate the fouling rate.

A model definition will show poor results when disturbances are not detected and therefore not quantified. These disturbances can be of different natures, e.g. process control malfunction, improper preparation of chemicals or wear out of equipment. Thus a precise and intensive maintenance program in addition to the measurement campaign is important for the successful application of statistical trial planning in pilot scale.

### **4.3 Ozonation and membrane filtration – What have we learned?**

The combination of ozonation and ceramic membrane filtration showed a beneficial effect on the filtration performance during short term trials. To achieve this positive effect a specific ozone dose between 0.6 - 0.8 mgO<sub>3</sub>/mgDOC is required, which is a similar dose than required for trace organic removal. The major reason for this beneficial effect is the transformation of biopolymers to smaller compounds, which can pass the membrane and less fouling occurs. This helps to overcome two major drawbacks in membrane filtration: Energy consumption due to high trans-membrane pressures and chemical requirements due to cleaning needs.

The WWTP Ruhleben shows a comparably high DOC concentration in the secondary effluent leading to comparably high ozone doses in order to maintain the targeted specific ozone dose of 0.6 - 0.8 mgO<sub>3</sub>/mgDOC, which leads to high costs for investment and operation. Additionally the beneficial effect of ozonation combined with ceramic membranes could not increase the sustainable flux in a way, that the extra costs for ozonation and the higher membrane costs compared to polymeric membranes are compensated.

The combination of ozonation and polymeric membranes (PES, ultrafiltration) showed an improved filtration performance when focusing on the resistance just before the backwash. Looking on the fouling resistance after the backwash, a resistance increase was observed even with a comparably low ozone dose (3 mgO<sub>3</sub>/L; ~0.2 mgO<sub>3</sub>/mgDOC). Both effects lead to similar mean resistances during operation with and without ozonation, thus the higher effort for implementation of an ozonation unit cannot be justified. It has to be noted that only the combination of PES ultrafiltration membranes were investigated in this report and that further lab scale experiments with diverse membrane types and pore sizes conducted at the Chair of Water Quality Control, TU Berlin, suggest a different behavior for microfiltration membranes, see report D4.2 by Godehardt et al. 2013.

## Bibliography

- Amy, G. 2009. Fundamental understanding of organic matter fouling of membranes. Desalination 231 44-51.
- Boulestreau, M., and U. Miehe. 2010. State of the art of the effect of coagulation and ozonation on membrane fouling; Project acronym: OXERAM 1.
- De la Torre, T., V. Iversen, A. Moreau, and J. Stüber. 2009. Filtration characterization methods in MBR systems: A practical comparison. Desalination and Water Treatment 9 (1-3): 15-21. 10.5004/dwt.2009.747
- EC. 2000. Directive 2000/60/EC. Official Journal of the European Communities.
- Filloux, E., H. Gallard, and J.-P. Croue. 2012. Identification of effluent organic matter fractions responsible for low-pressure membrane fouling. Water Research. 10.1016/j.watres.2012.07.034
- Genz, C., U. Miehe, R. Gnirss, and M. Jekel. 2011. The effect of pre-ozonation and subsequent coagulation on the filtration of WWTP effluent with low-pressure membranes. Water Science & Technology 64 (6): 1270–1276. doi:10.2166/wst.2011.724
- Godehardt, M., G. Aschermann, and M. Jekel. 2013. Role of organic substances in tertiary treatment via oxidation and membrane filtration - Final report OXERAM. Kompetenzzentrum Wasser Berlin gGmbH. [www.kompetenz-wasser.de](http://www.kompetenz-wasser.de)
- Haberkamp, J., A. S. Ruhl, M. Ernst, and M. Jekel. 2007. Impact of coagulation and adsorption on DOC fractions of secondary effluent and resulting fouling behaviour in ultrafiltration. Water Research 41 (17): 3794-3802.
- Haberkamp, J. 2008. Organisches Membranfouling bei der Ultrafiltration kommunaler Kläranlagenabläufe: Ursachen, Mechanismen und Maßnahmen zur Verringerung. Doktor der Ingenieurwissenschaften. Fakultät III – Prozesswissenschaften der Technischen Universität Berlin.
- Haberkamp, J., M. Ernst, U. Bockelmann, U. Szewzyk, and M. Jekel. 2008. Complexity of ultrafiltration membrane fouling caused by macromolecular dissolved organic compounds in secondary effluents. Water research 42 3153 – 3161.
- Huber, S. A., A. Balz, M. Abert, and W. Pronk. 2011. Characterisation of aquatic humic and non-humic matter with size-exclusion chromatography – organic carbon detection – organic nitrogen detection (LC-OCD-OND). Water Research 45 (2): 879-885. 10.1016/j.watres.2010.09.023
- Kim, S.-H., S.-Y. Moon, C.-H. Yoon, S.-K. Yim, and J.-W. Cho. 2005. Role of coagulation in membrane filtration of wastewater for reuse. Desalination 173 (3): 301-307.
- Lehman, S. G., and L. Liu. 2009. Application of Ceramic Membranes with Pre-Ozonation for Treatment of Secondary Wastewater Effluent. Water Research 43 (7): 2020-2028. 10.1016/j.watres.2009.02.003
- Panglisch, S., G. Kraus, A. Tatzel, and J.-P. Lickes. 2010. Membrane performance in combined processes including ozonation or advanced oxidation, powdered activated carbon and coagulation — Investigations in pilot scale. Desalination 250 (2): 819-823. 10.1016/j.desal.2008.11.049
- Remy, C. 2013. Life Cycle Assessment and Life Cycle Costing of tertiary treatment schemes - Final report OXERAM. Kompetenzzentrum Wasser Berlin gGmbH. [www.kompetenz-wasser.de](http://www.kompetenz-wasser.de)
- Roorda, J. H., S. te Poele, and J. H. J. M. Van der Graaf. 2004. The role of microparticles in dead-end ultrafiltration of wwtp-effluent. Water science and technology 50 (12): 87-94.
- Schwankhart, M., and M. Krug. 2012. Membrane Investigation Report. Inge GmbH.
- Stüber, J. 2011. Erste Betriebserfahrungen - Keramikmembran 3C - Internal report. Kompetenzzentrum Wasser Berlin gGmbH.
- Te Poele, S. 2006. Foulants in ultrafiltration of wwtp effluent. PhD. Delft University of Technology. urn:NBN:nl:ui:24-uuid:42fffa7-a729-4a2b-b637-558f4104e5ac

- Trussel, S., S. Adham, and R. Trussel. 2005. Process Limits of Municipal Wastewater Treatment with the Submerged Membrane Bioreactor. Journal of Environmental Engineering 131 (3): 410-416. doi 10.1061/(ASCE)0733-9372(2005)131:3(410)
- Van Geluwe, S., L. Braeken, and B. Van der Bruggen. 2011. Ozone oxidation for the alleviation of membrane fouling by natural organic matter: A review. Water Research 45 (12): 3551-3570.
- Wang, X., L. Wang, Y. Liu, and W. Duan. 2007. Ozonation pretreatment for ultrafiltration of the secondary effluent. Journal of Membrane Science 287 (2): 187-191.
- Zheng, X., M. Ernst, and M. Jekel. 2009. Identification and quantification of major organic foulants in treated domestic wastewater affecting filterability in dead-end ultrafiltration. Water Research 43 238-244.
- Zheng, X. 2010. Major Organic Foulants in Ultrafiltration of Treated Domestic Wastewater and their Removal by Bio-filtration as Pre-treatment. Chair of Water Quality Control, Technische Universität Berlin. ISBN 978-3-89720-557-4.
- Zietzschmann, F. 2011. Biopolymer fouling in ultrafiltration of surface water and treated domestic wastewater. Diploma Thesis. Fachgebiet Wasserreinhaltung, TU Berlin.

## Appendix

**Table 21: Work sheet Polymeric Membrane (UF2) - Statistical Trial Planning**

Exp No	Run Order	Time of Filtration	Flux	Backwash time	Coagulant dosage
4	1	30	45	55	8
18	2	60	45	55	4
3	3	30	75	55	4
10	4	30	45	35	12
14	5	30	45	35	4
2	6	45	60	45	8
1	7	60	75	55	4
17	8	60	45	35	12
16	9	30	75	55	12
7	10	60	75	35	4
6	11	30	75	35	12
5	12	60	75	55	12
8	13	45	60	45	4
12	14	60	45	35	4
9	15	30	45	55	12
11	16	60	75	35	12
13	17	45	60	45	8
19	18	60	45	55	12
15	19	30	75	35	4

**Table 22: Work sheet Ceramic Membrane - Statistical Trial Planning**

Exp No	Run Order	Time of Filtration	Flux	Coagulant dosage	Ozone
7	1	60	120	12	15
1	2	30	60	8	0
9	3	30	120	12	15
15	4	45	90	8	7,5
13	5	30	120	4	15
12	6	60	120	4	15
2	7	30	120	12	0
8	8	30	120	4	0
6	9	30	60	12	0
17	10	45	90	8	7,5
18	11	60	60	4	15
14	12	60	60	12	15
11	13	60	120	4	0
19	14	30	60	12	15

10	15	30	60	4	15
4	16	45	90	8	7,5
16	17	60	60	12	0
5	18	60	120	12	0
3	19	60	60	4	0

**Table 23: Coefficient table of fouling rate model: Trial phase1 UF2**

	<b>Coeff. SC</b>	<b>Std. Err.</b>	<b>P</b>	<b>Conf. int(±)</b>
<b>Constant</b>	3.27E+16	3.55E+15	4.66E-02	7.66E+15
Time of filtration tf	4.43E+15	3.88E+15	0.274189	8.38E+15
Flux	1.30E+15	3.88E+15	0.00521834	8.38E+15
Coagulant dosage Coa	-1,71e+011	3.91E+14	0.000751409	8.44E+15
Flux*Coa	-8.56E+15	4.04E+15	0.053833	8.72E+15
<b>Statistics</b>				
N = 18	Q2 =	0,582	Cond. no. =	1,233
DF = 13	R2 =	0,748	RSD =	1.50E+14
	R2 Adj. =	0,671		
			Conf. lev. =	0,95